



OPHI WORKING PAPER NO. 125

Measuring Autonomy: Evidence from Bangladesh

Ana Vaz*, Sabina Alkire**, Agnes Quisumbing***

and Esha Sraboni****

March 2019

Abstract

The search for rigorous, transparent, and domain-specific measures of empowerment that can be used for gendered analysis is ongoing. This paper explores the value-added of a new measure of domain-specific autonomy. This direct measure of motivational autonomy emanates from the 'self-determination theory' (Ryan and Deci, 2000). We examine in detail the Relative Autonomy Index (RAI) for individuals, using data representative of Bangladeshi rural areas. Based on descriptive statistical analyses, we conclude that the measure and its scale perform broadly well in terms of conceptual validity and reliability. Based on an exploratory analysis of the determinants of autonomy of men and women in Bangladesh, we find that neither age, education, nor income are suitable proxies for autonomy. This implies that the RAI adds new information about the individuals and is a promising avenue for further empirical exploration as a quantitative yet nuanced measure of domain-specific empowerment.

Keywords: empowerment, agency, social indicators, Bangladesh

JEL classification: D63, O55

* Oxford Poverty and Human Development Initiative (OPHI), ana.vaz@qeh.ox.ac.uk.

** Oxford Poverty and Human Development Initiative (OPHI), sabina.alkire@qeh.ox.ac.uk.

*** International Food Policy Research Institute, a.quisumbing@cgiar.org.

**** Brown University, Esha_Sraboni@brown.edu.

This study has been prepared within the OPHI theme on multidimensional measurement.

Acknowledgements

We wish to thank Giulia Greco, Naomi Hossain, Kathryn Yount, Christoph Jindra and Richard Ryan for very helpful comments and suggestions. OPHI gratefully acknowledges support from the International Food Policy Research Institute (IFPRI).

Citation: Vaz, A., Alkire, S., Quisumbing, A., and Sraboni, E. (2019). 'Measuring autonomy: Evidence from Bangladesh', OPHI Working Paper 125, University of Oxford.

The Oxford Poverty and Human Development Initiative (OPHI) is a research centre within the Oxford Department of International Development, Queen Elizabeth House, at the University of Oxford. Led by Sabina Alkire, OPHI aspires to build and advance a more systematic methodological and economic framework for reducing multidimensional poverty, grounded in people's experiences and values.

The copyright holder of this publication is Oxford Poverty and Human Development Initiative (OPHI). This publication will be published on OPHI website and will be archived in Oxford University Research Archive (ORA) as a Green Open Access publication. The author may submit this paper to other journals.

This publication is copyright, however it may be reproduced without fee for teaching or non-profit purposes, but not for resale. Formal permission is required for all such uses, and will normally be granted immediately. For copying in any other circumstances, or for re-use in other publications, or for translation or adaptation, prior written permission must be obtained from OPHI and may be subject to a fee.

Oxford Poverty & Human Development Initiative (OPHI)
Oxford Department of International Development
Queen Elizabeth House (QEH), University of Oxford
3 Mansfield Road, Oxford OX1 3TB, UK
Tel. +44 (0)1865 271915 Fax +44 (0)1865 281801
ophi@qeh.ox.ac.uk <http://www.ophi.org.uk>

The views expressed in this publication are those of the author(s). Publication does not imply endorsement by OPHI or the University of Oxford, nor by the sponsors, of any of the views expressed.

1. Introduction

Agency, and in particular women's agency, continues to have a prominent role in the development and poverty debate. For example, in *An Uncertain Glory: India and its Contradictions*, Jean Drèze and Amartya Sen call for further analyses to probe the links between women's agency and developmental outcomes in Bangladesh, and suggest that, to a great extent, transformations in 'women's agency and gender relations account for the fact that Bangladesh has caught up with, and even overtaken, India in many crucial fields during the last twenty years' (Drèze and Sen 2013, p. 61).

But, how do we probe links between women's agency and development outcomes in Bangladesh? Quantitative studies of agency and its relationship to other variables remain curtailed by the unfinished search for adequate indicators of women's empowerment within the household and other social institutions, in economic activities, and in political space (Samman and Santos, 2009; Ibrahim and Alkire, 2007; Narayan, 2005; Alsop, Bertelsen and Holland, 2006; and Malhotra, Schuler and Boender, 2002). At present, women's agency is most commonly measured through proxies such as education, employment, violence, ownership, control of assets such as land or housing, control over income, and so on. The use of proxy measures faces several problems, especially when the proxies represent development outcomes that agency is understood to advance (Alkire, 2008). Other common indicators of women's empowerment for intra-household relations – decision-making in different domains, attitudes towards gender roles such as wife beating, and exposure to information – also face challenges. For example, Kishor and Subaiya's detailed study of 23 different empowerment indicators concluded that there was no single adequate indicator of empowerment. They also found that policy-relevant determinants of empowerment differed across countries and regions within countries: 'different facets of women's empowerment do not all relate in the same way to one another or to various explanatory variables' (2008, p. 201). Because gender norms are culture- and context-specific, the variation in the strength and significance of these relationships across countries should not be surprising. Yet, this does not negate the need for better indicators of women's agency.

This paper explores the value-added of a direct measure of domain-specific autonomy in the context of Bangladesh. The rich existing literature on empowerment in Bangladesh enables us to spot more easily duplication and value-added of analyses more directly than in contexts that have not been the subject of the same extent of qualitative and quantitative studies.

The measure under scrutiny in this paper is a domain-specific measure of motivational autonomy proposed by Ryan and Deci (2000) and emanates from what is known as 'self-determination theory' (SDT): the Relative Autonomy Index (RAI). This measure of autonomy is particularly suitable to the analysis of human development and poverty (Alkire, 2005, 2008). First, its definition is very similar to the one

proposed by Sen's capability approach. Second, the SDT approach is conceptually one of the most advanced psychological approaches to motivational autonomy and self-determination, and it has been operationalized and well-validated across different nations (Chirkov, 2009; Chirkov et al., 2011). Third, it is flexible: the domains can be chosen to suit the particular analysis or poverty context. Fourth, the RAI does not replicate any existing measure of poverty, which may facilitate analyses of the interaction between poverty and agency. Fifth, the measure empirically seeks to reflect the individual's own values, rather than fixing a definition of autonomy from outside or relying on purely subjective responses. Sixth, the measure appears to be cross-culturally comparable (and the assumption can be re-tested in this and future studies). Furthermore, the measure seems to frame autonomy in a way that is valued in individualistic and collectivist cultures alike – which is critically important as most indicators of agency are correlated with individualism (Chirkov et al., 2003). This is important in the case of Bangladesh because concepts of agency and autonomy, which tend to be interpreted in terms of individual autonomy, need to be considered in light of Bangladeshi women deriving personal identity and satisfaction from relationships in which they are embedded.¹

Our analyses uncover new insights on the linkages between men's and women's autonomy and other development outcomes such as income, education, and occupation, as well as personal characteristics such as age and household composition. The analyses also document the extent to which the autonomy indicator supplies new information that is not present in measures of household decision-making. While empowerment must be approached using multiple indicators and with a deep contextual understanding, it is possible that the RAI could prove to be a particularly useful tool for policy-relevant analyses.

As far as we know, the only other application of the RAI to measure women's autonomy in the context of a developing country and based on data from a large-scale household survey was conducted by Vaz, Pratley, and Alkire (2015). They found evidence that neither education nor income are reasonable proxies for women's motivational autonomy in Chad.

This paper proceeds as follows. The next section presents the conceptual framework. Section 3 introduces the data. Section 4 presents and discusses the conceptual validity and reliability analyses. Section 5 discusses to what extent the RAI adds information to the standard socio-economic and demographic variables and decision-making indicators. Section 6 concludes.

¹ Kathryn Yount, personal communication, May 5, 2014. This is consistent with findings from qualitative studies undertaken to supplement the pilot surveys of the Women's Empowerment in Agriculture Index; in Bangladesh, individuals cite a communal, rather than a singular, understanding of empowerment focused on the family unit rather than the individual woman or man – which includes the ability to work jointly and well together. Therefore, doing work and income-generating activities successfully empowers not just an individual but an entire family (Becker 2012).

2. Conceptual Framework

The Self-Determination Theory (SDT), developed by psychologists Richard Ryan and Ed Deci and others (Chirkov, Ryan, and Sheldon, 2011; Ryan and Deci 2000; Deci and Ryan, 2012), distinguishes types of motivation depending on the degree to which they are self-determined (versus controlled). Human behavior is driven by intrinsic and extrinsic motivations. Intrinsic motivation is associated with the enjoyment of the activity in itself (for example, ‘exercising because I really enjoy it’); while extrinsic motivation is the adoption of a behavior in an instrumental way, i.e. in order to obtain an outcome aside from the behavior itself (‘exercising to lose weight and/or improve health’). The SDT differentiates four types of extrinsic motivation, depending on the degree to which the individual self-endorses the behavior: external, introjected, identified, and integrated. External motivation occurs when there is effective coercion by other people or by force of circumstances (‘exercising because otherwise my partner will be very upset at me’). Introjected motivation is when the individual acts to please others or to avoid blame (‘exercising to avoid that my friends think poorly of me’). Identified motivation occurs when the person’s behavior reflects the valuing of self-selected goals and activities (‘exercising because I think it is important for my health’). Integrated motivation occurs when the person’s actions reflect her own system of values, goals, and identities, fully considered (‘exercising because I see myself as a person that regularly exercises’). These types of extrinsic motivation reflect a self-determination continuum. External and introjected motivations are associated with relatively controlled behavior, ‘in which one’s actions are experienced as controlled by forces that are phenomenally alien to the self, or that compels one to behave in specific ways regardless of one’s values or interests’ (Chirkov et al., 2003). Identified and integrated motivations are associated with relatively autonomous behavior, which is experienced willingly and it is fully endorsed by the individual. Figure A.1 in the Appendix summarizes the conceptual definitions of the self-determination continuum.

Within this framework, the RAI measures the extent to which the individual’s motivation for her behavior in a specific domain is fairly autonomous as opposed to somewhat controlled. Thus, the RAI can be seen as a direct measure of the individual’s ability to act on what she values. The RAI is computed with reference to a specific area of decision-making and, hence, allows us to examine variations in the individual’s degree of autonomy across different aspects of her life.

The distinction between all types of motivations is not relevant in every context (Ryan and Connell, 1989; Levesque et al., 2007). In our analysis we combined the different forms of autonomous motivation (identified, integrated, and intrinsic) into one single subscale. Thus, we use three subscales: external, introjected, and autonomous motivation. The specific questions that we use to measure each subscale are based on the SDT Self-Regulation questionnaires and were revised through several field exercises (Alkire, 2005; Alkire et al., 2013). These questions ask individuals to rate each of three possible motivations for

their actions in a specific domain, ranging from ‘never true’ (lowest score, 1) to ‘always true’ (highest score, 4). The wording of the survey questions are presented in Table 1.

The RAI is the weighted sum of the person’s scores in the three subscales. The subscales weights are a function of their position in the self-determination continuum: –2 for external motivation, –1 for introjected motivation, and +3 for autonomous motivation. The RAI, thus, varies between -9 and 9. The structure of the RAI is summarized in Table 1. Positive scores are interpreted as indicating that the individual’s motivation for her behavior in that specific domain tends to be relatively autonomous; while negative scores indicate a relatively controlled motivation.

Table 1: Structure of Relative Autonomy Index

Type of motivation	Survey question: Your actions with respect to [Domain] are	Range / Scale	Weight	
External	Motivated by a desire to avoid punishment or gain reward?	1–4	Never true – Always true	-2
Introjected	Motivated by a desire to avoid blame or so that other people speak well of you?	1–4	Never true – Always true	-1
Autonomous	Motivated by and reflect your own values and/or interests?	1–4	Never true – Always true	3

3. Data

We use data from the Bangladesh Integrated Household Survey (BIHS),² conducted from December 2011 to March 2012. The BIHS sample is nationally representative of rural Bangladesh and representative of rural areas in each of the seven administrative divisions of the country (Sraboni et al., 2013a, 2013b).

The BIHS questionnaires include a module specifically designed to collect data for computing the pilot Women’s Empowerment in Agriculture Index (WEAI) (Alkire et al., 2013). This module includes the autonomy questions that provide the data to construct the RAI. This module covers 13 domains of decision-making (Table 2).

The total sample size is 5,500 households, with information regarding both the self-identified primary male and female decision-makers in 4,566 of these households.³ However, as, in each domain of decision-

² Accessible [here](#).

³ For 932 households, we have information only for a female respondent (310 are single female-headed households, 559 are married female-headed households, and 63 were male-headed households). For five households we have only information for the male respondent.

making, autonomy information was only provided by those respondents who actually make decisions in that domain, the relevant sample in each domain is smaller and varies across domains (Table 2).

Table 2: Size of the sample with information to compute RAI

Domain		Men	Women
a	Agricultural production	2,886	2,637
b	What inputs to buy for agricultural production	2,852	2,599
c	What types of crops to grow for agricultural production	2,853	2,620
d	When or who would take crops to the market	2,664	2,489
e	Livestock raising	2,813	3,232
f	Nonfarm business activity	2,224	1,607
g	Your own wage or salary employment	2,641	1,974
h	Minor household expenditures	4,506	5,168
i	What to do if you have a serious health problem	3,989	4,801
j	How to protect yourself from violence	1,663	1,525
k	Whether and how to express religious faith	3,850	3,839
l	What kind of tasks you will do on a particular day	4,268	5,063
m	Whether or not to use family planning to space or limit births	3,401	4,097

4. Conceptual Validity and Reliability

This section focuses on assessing how well the RAI measures the autonomy of individuals.

4.1 Conceptual Validity

First, we examine whether the data collected is consistent with the main hypotheses of our measurement model:

- (1) There are three dimensions in our autonomy data. Each of these dimensions reflects one of the latent constructs that we are attempting to measure: external, introjected, and autonomous motivations.
- (2) There is an ordered correlation among the motivation subscales. As the subscales correspond to a continuum of autonomy, we expect that adjacent subscales will correlate more strongly than subscales further apart on the continuum (Ryan and Connell, 1989).⁴

⁴ While the terminology might be interpreted to imply that identified motivation is negatively correlated with external and introjected motivations, the external and identified motivations are not necessarily negatively correlated, but are likely to have very low correlations since they are on the opposite extremes of the scale (Ryan, personal communication).

4.1.1 Dimensional Structure

In this section we examine the structure of the full set of motivation questions. We investigate the feasibility of a three-dimension structure, in which each dimension captures one of the latent characteristics that we are attempting to measure: external, introjected, and autonomous motivations.

The main limitation of this approach in this context is that it disregards the domain-specific nature of our autonomy measure. In other words, it assumes that questions about the same type of motivation, but which refer to different areas of decision-making, load on a common factor. We believe that this assumption may be verified in the context of closely related areas of decision-making.

Following Guio, Gordon, and Marlier (2012), we analyze the structure of the data using three different statistical methods: a factor analysis, a multiple correspondence analysis, and a cluster analysis. The three methods lead to similar conclusions. Here we discuss the confirmatory factor analysis. The results of the exploratory factor analysis, multiple correspondence analysis, and cluster analysis can be found in the Appendix.

We perform a Confirmatory Factor Analysis (CFA) to investigate how well our measurement model fits the data. We consider a model with three latent constructs, each one measured with four indicators, one for each area of decision-making related to agriculture (agriculture production, what inputs to buy, what crops to grow, and who takes the crops to the market and when).⁵ The CFA model is displayed in Figure 1.

The factor loadings⁶ of all items are very high, always above 0.75, and statistically significant at the 1% level. The items with the lowest factor loadings are the ones aimed at capturing introjected motivation. The measure's Standardized Root Mean Square Residual (SRMR), 0.015, suggests a good fit, as it is far

⁵ We did not perform the Confirmatory Factor Analysis with reference to all 13 domains because only 636 individuals participate in decisions on all 13 domains. We focused on the agriculture-related domains because these are the ones that are more correlated.

⁶ Under our fully standardized and simple structure model, these factor loadings can be interpreted as correlation coefficients between each item and the corresponding latent factor (Abell, Springer, and Kamata, 2009).

Figure 1: CFA Model – All sample

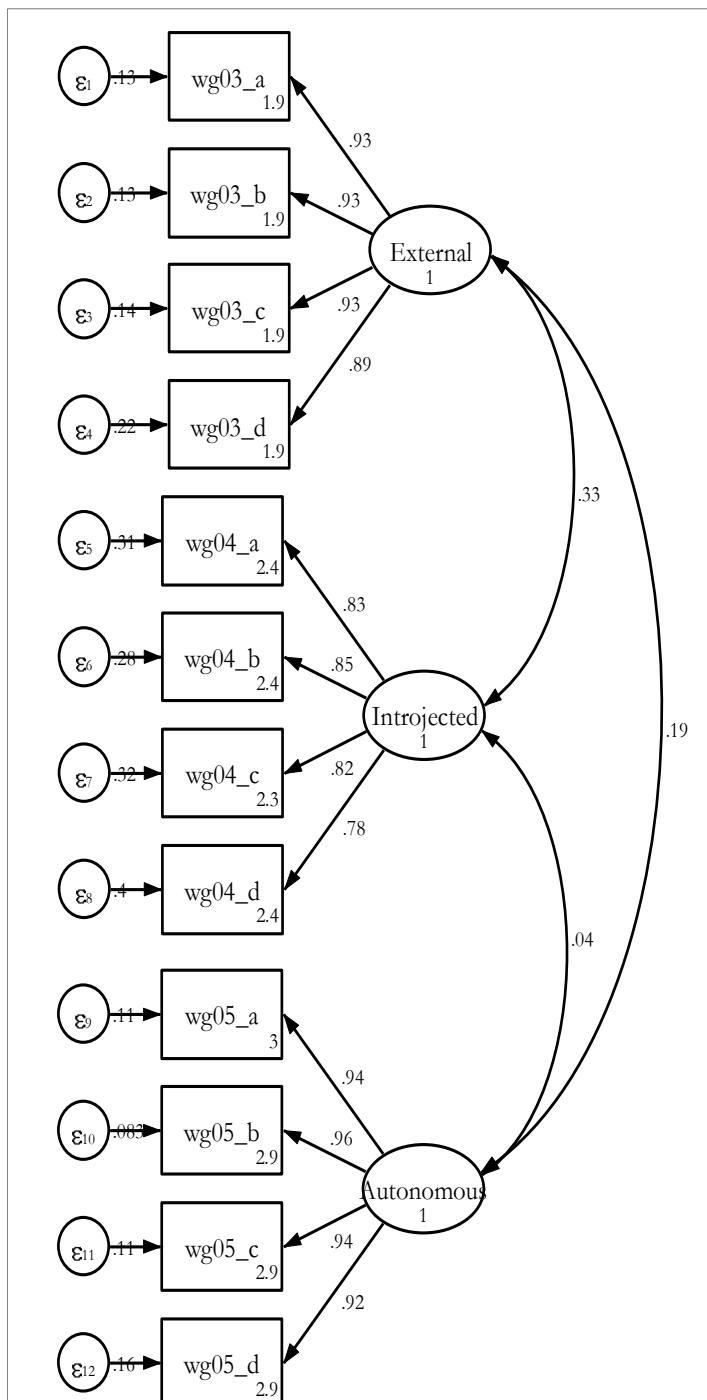

below the threshold 0.1, and the Coefficient of Determination (CD) suggests a perfect fit.⁷ So, we conclude that the CFA confirms that our measurement model fits the data. In order to examine parameters' invariance across gender, we estimate the same model separately for men and women. The CFA models for the sample of women and men are displayed in the Appendix. The factor loadings in the models of men and women are very similar, although the ones for women tend to be slightly higher; and, in the case of the items loading into the external motivation factor, the 95% confidence intervals of men and women's estimates do not overlap, which implies that at least these parameters are statistically different for men and women at a significance level of 5%. The biggest difference between the two models is in terms of the covariance between the latent factors. In the sample of men, the factors external and introjected are strongly correlated, and they are both weakly correlated with the autonomous factor. In the sample of women, the highest correlation occurs between the external and autonomous factors.⁸ If the external

⁷ Ignoring the survey design, we obtain a model with loadings, intercepts, and variances almost identical to the ones displayed in Figure 2. For this model STATA produces a larger range of goodness of fit indices and statistics. The chi-square statistic is significant; although this does not support a good fit it is almost unavoidable given the size of the sample. The Root Mean Square Error of Approximation (RMSEA) and the lower and upper bounds of its 90% confidence interval meet the standards for an acceptable fit. The Comparative Fit Index (CFI) and the Tucker-Lewis Index (TLI) are above the threshold for an excellent fit.

⁸ Considering only the sampling weights (and ignoring the strata and the primary sampling units), we estimated the same model allowing all parameters except the measurement intercepts to vary across gender. Then, using Stata's command estat ginvariant (which is not available for estimations considering complex survey designs), we performed 'score tests (Lagrange multiplier tests) and Wald tests of whether parameters constrained to be equal across groups should be relaxed and whether parameters allowed to vary across groups could be constrained' (StataCorp, 2013)). Looking at the joint tests for each

constraints for both genders reflect economic constraints, cultural hypotheses could be explored (to give a very basic example, male introjection could refer to social norms of being able to care for the family, and female's self-valuing of autonomous activities may be shaped by the extent to which these activities serve the family's needs). Obviously, this requires further exploration.

We also found no evidence that the items of our measurement model might be capturing different abilities across people of different ages, or people with different education levels or between people who are employed and unemployed.

This analysis suggests that there is a three-factor structure in the data and that each question loads into the factor that it is supposed to. It also suggests that the measurement model might vary across gender. Finally, the correlations between the latent factors do not follow the ordered pattern hypothesized by the theory, especially in the sample of women. This feature requires further study. It may be that future research should explore discriminating between economic or 'necessity-based' external motivations (gain economic reward, survive a serious health problem, prevent conception) and social external motivations (avoid punishment and coercion). Ryan and Deci focus more on social external motivations. Introjection clearly refers to milder social restrictions than punishment. However, if the external motivations relate to economic constraints and not a higher intensity of external social restrictions, then the anticipated continuum needs not hold. That possibility – which may have influenced women's responses in particular – is worth exploring and for that reason we are not too disturbed by the correlation patterns as they clearly distinguish between the three factors.

4.1.2 Correlations within Areas of Decision-making

The subscales are expected to correspond to a continuum of autonomy. If they do, we expect contiguous subscales to correlate more strongly than subscales in opposite extremes. Thus, we expect the lowest correlation to occur between external and autonomous motivations. To investigate this we compute Spearman and Pearson correlation matrices for each domain, considering the samples of men and women separately.⁹ The matrices are presented in Table A.2 in the Appendix.

parameter class, the null hypotheses that the measurement coefficients (chi-square of 45.862 and 9 degrees of freedom), the covariance of measurement errors (chi-square 75.212 with 12 degrees of freedom) and the covariance of exogenous variables (chi-square of 235.969 with 6 degrees of freedom) could be constrained across gender are rejected, and the null hypothesis that the measurement intercepts should be invariant across gender (chi-square 54.410 with 9 degrees of freedom) is also rejected. Looking at the single indicators tests, we find that the number of rejections is highest among parameters related to the variables that load into the external factor, which may suggest that men and women face different external constraints to their actions.

⁹ Spearman correlation coefficients do not take into account the survey design. The Pearson correlation coefficients displayed were computed pairwise and they take into account the survey design.

We observe very distinct patterns of correlation for men and women. In the sample of men, we find that external and introjected motivations are strongly correlated in all domains, with the average correlations of 0.4 or 0.5; and that both of these controlled forms of motivation correlate weakly with autonomous motivation (the absolute value of the correlation coefficients is below 0.08 in most domains).

In the sample of women, we find that external motivation is significantly correlated with both introjected and autonomous motivations, but the values are lower. In five domains related to economic activities ('agriculture production', 'what inputs to buy', 'what crops to grow', 'non-farming business activity' 'own wage and salaried employment'), external motivation is more correlated with autonomous than with introjected motivation. The correlations between external motivation and autonomy range from 0.16 to 0.25, except in the case of non-farm business where correlation rises to 0.33. The correlation between autonomy and introjection is only greater than 0.11 for the definition of daily tasks, where it is 0.138. A potential explanation for this pattern of correlation is that women in Bangladesh tend to internalize societal norms and 'make them their own'; Bangladeshi women also derive personal value from their collective identity as member of a family (Becker 2012). Another option is that women's motivations in these domains are heavily controlled, even if they are also autonomous. For example, all of the productive activities may be primarily done for (financial) reward – so external motivations will contribute to all of them. In such a case, the degree of women's autonomy will be distinguished more by the strength of autonomous motivations than by low external motivations – because indeed external motivations (in particular the need to work in order to obtain benefit) seem high. Qualitative work is required to probe this issue further. This divergence of the correlation patterns does raise questions about whether the weighted aggregation structure of the RAI can be interpreted in the same way for men and women.

4.2 Reliability

We test the internal consistency of motivation subscales using Cronbach's Alpha. This familiar coefficient reflects the extent to which a set of items measures a latent construct. Generally, in social sciences an Alpha above 0.7 is understood as 'satisfactory', above 0.8 is seen as 'good', and above 0.9 is considered 'excellent'.

We compute Cronbach's Alpha for each autonomy subscale considering different areas of decision-making, similar to the approach adopted in the analysis of dimensional structure.¹⁰ We start by computing Alpha considering all areas of decision-making (13 items). As the number of items can artificially inflate

¹⁰ Cronbach's Alpha is suitable to test the reliability of multiple-items scales. In our model, each autonomy subscale related to a specific area of decision-making is measured with only one question. Therefore, it is not possible to assess internal consistency of autonomy subscales within areas of decision-making.

Alpha (Cortina, 1993), we also calculate Alpha considering only the areas of decision-making related to agriculture (four items) and considering only the domains not related to economic activities (six items).

Table 3: Cronbach's Alpha for different autonomy subscales, considering different sets of domains and different samples

	External motivation	Introjected motivation	Autonomous motivation	No. of observations
All items				
Sample of men	0.9552	0.9493	0.9866	365
Sample of women	0.9927	0.9066	0.9733	271
Items related to agriculture				
Sample of men	0.9278	0.8811	0.9693	2,608
Sample of women	0.9723	0.9019	0.9609	2,302
Items not related to economic activities				
Sample of men	0.9267	0.9011	0.9606	1,272
Sample of women	0.9623	0.8723	0.9519	1,104

Table 3 shows that Cronbach's Alpha for external and identified motivation subscales are 'excellent' in every case, ranging from 0.93 to 0.99. The introjected motivation has slightly lower Alphas, but they are 'good' or 'excellent', always above 0.87, thus confirming the consistency of motivation scales.

We also performed an additional analysis of reliability using nonparametric Item Response Theory (IRT), the Mokken Scale Procedure (Hemker, Sijtsma, and Molenaar, 1995, p. 337). The results are presented in the Appendix and broadly validate the reliability of the RAI.

5. External Validity

Our main hypothesis is that the autonomy indicators yield new and valuable information that is not contained in standard socio-economic and demographic variables. If this is the case, its measurement and analysis could provide additional information. If not, some proxy variable may be sufficient for the same analysis. In this section we try to identify the determinants of autonomy and examine to what extent this concept is captured by other common proxies for empowerment, particularly decision-making.

The average RAIs for the different domains, across different population sub-groups are presented in the Online Appendix.

5.1 Correlations

In this section we examine the correlation between the relative autonomy indicators and a set of common proxies of empowerment. We start by looking at the correlations with the indicators of general

functionings: (i) individual's education level and (ii) per capita expenditure quintile to which the household belongs. Then, we look at the relationship with general indicators of empowerment and agency. As general indicators of empowerment we use the 10-step ladder questions about respondent's satisfaction with her: power to make important decisions that change the course of one's life; possibilities of going to other places outside one's village; and contact with friends or relatives. As general indicators of agency we used the indicator 'ability to change things in the community'¹¹ and 'influence in the community', based on a 9-step ladder question.¹² Finally, we look at correlations with the indicator of whether the individual feels she can make her own personal decisions in that specific domain¹³ and the indicator of the individual's satisfaction with her decisions in that domain.

Table 4: Pearson correlations between RAI and other indicators

RAI	General functioning		Empowerment			Agency		Domain-specific functionings	
	Education	Income	Power to make decisions	Mobility	Contact friends & relatives	Make changes in community	Influence in community	Feel make decisions	Satisfaction with decisions
	(1)	(2)	(3)	(4)	(5)	(6)	(7)	(8)	(9)
Panel A: Sample of men									
Agricultural production	0.02	0.18***	0.23***	0.26***	0.35***	0.03	0.08***	0.08**	0.39***
Purchase inputs	0.04	0.17***	0.23***	0.27***	0.36***	0.03	0.08***	0.05	0.38***
Decide on crops	0.03	0.16***	0.21***	0.25***	0.33***	0.03	0.08***	0.07**	0.40***
Take crops to markets	0.03	0.16***	0.23***	0.26***	0.35***	0.04*	0.09***	0.07**	0.42***
Livestock raising	0.03	0.18***	0.23***	0.24***	0.34***	0.05**	0.10***	0.09***	0.40***
Non-farm activity	0.03	0.17***	0.24***	0.28***	0.34***	0.07***	0.13***	0.05*	0.43***
Wage and employment	0.07***	0.17***	0.24***	0.24***	0.34***	0.04	0.07**	0.06**	0.49***
Minor household expenditures	0.04**	0.13***	0.21***	0.23***	0.30***	0.03	0.05**	0.01	0.34***
Health	0.01	0.14***	0.21***	0.25***	0.29***	0.08***	0.11***	0.03	0.41***
Protection from violence	0.08***	0.26***	0.18***	0.19***	0.28***	0.24***	0.16***	-0.04	0.40***
Religious faith	0.02	0.11***	0.11***	0.14***	0.15***	-0.04	0.02	0.03	0.26***
Daily tasks	0.01	0.14***	0.16***	0.23***	0.31***	0.00	0.04*	0.08***	0.37***
Family planning	0.01	0.08***	0.19***	0.24***	0.25***	0.03	0.04	0.11***	0.26***
Panel B: Sample of women									
Agricultural production	0.05**	0.07**	0.18***	0.15***	0.14***	0.08**	0.10***	0.07**	0.28***

¹¹ The wording of the respective question is 'Do you feel that a [man / woman] like yourself can generally change things in the community where you live if s/he wants to?'. And the answer scale is 1 'No, not at all', 2 'Yes, but with a great deal of difficulty', 3 'Yes, but with a little difficulty', 4 'Yes, fairly easily', and 5 'Yes, very easily'.

¹² The wording of the question is 'Please imagine a nine-step ladder, where on the bottom, the first step, stand people who have NO influence on the community, and step 9, the highest step, stand those who have influence in the community. On which step are you?'

¹³ We consider the definition used in the context of Women's Empowerment in Agriculture Index: the indicator assumes a value of one if the individual make makes the decisions, or if feels she could make it to a medium extent if she wanted (Alkire et al., 2013).

Purchase inputs	0.05**	0.09***	0.20***	0.18***	0.17***	0.07**	0.12***	0.08***	0.30***
Decide on crops	0.06**	0.08***	0.19***	0.15***	0.15***	0.07**	0.11***	0.08***	0.30***
Take crops to markets	0.05*	0.10***	0.20***	0.15***	0.17***	0.08**	0.11***	0.09***	0.30***
Livestock raising	0.01	0.07***	0.13***	0.09***	0.10***	0.07**	0.11***	0.10***	0.33***
Non-farm activity	0.06*	0.12***	0.15***	0.15***	0.13***	0.08*	0.10**	0.10***	0.32***
Wage and employment	0.04	0.05	0.10***	0.11***	0.11***	-0.01	0.03	0.04	0.30***
Minor hh expenditures	0.02	0.05**	0.14***	0.10***	0.08***	0.04	0.08***	0.07***	0.33***
Health	0.02	0.06**	0.15***	0.12***	0.11***	0.05*	0.10***	0.03	0.32***
Protection from violence	0.08**	0.03	0.11**	0.09*	0.18***	-0.03	-0.02	0.11***	0.37***
Religious faith	0.06**	0.09***	0.09**	0.07**	0.03	0.07**	0.06**	0.04	0.33***
Daily tasks	0.02	0.09***	0.09***	0.07***	0.07***	0.06**	0.07***	0.08***	0.30***
Family planning	0.04**	0.06**	0.12***	0.07***	0.06**	0.06**	0.12***	0.01	0.33***

We examine the Pearson correlation coefficients, which allow us to account for the survey design (Table 4). We report the Spearman and Kendall tau rank correlations in the Appendix. Contrary to what is commonly assumed, we find that autonomy is not highly correlated with education; although the coefficient is significant in some domains, it never goes beyond 0.08. Autonomy is also not strongly correlated with expenditure quintile. Although the correlation coefficient is almost always statistically significant, the magnitude is relatively small. The correlation between autonomy and income is consistently higher among men (average of 0.16 across domains) than among women (average of 0.07).

The three indicators of empowerment are correlated with autonomy in practically all domains. Again, the magnitude of this correlation is, on average, higher in the sample of men than in the sample of women. And again, the correlation levels are modest. This time, correlation levels for men between autonomy and empowerment reach 0.24 for decision-making; 0.28 for mobility, and 0.35 for contact with friends and relatives. Women's correlations are lower and more uniform across the empowerment indicators, and never above 0.20. The correlations with the indicators of agency are in general relatively weak and not significant in all domains.

We find that the RAI and satisfaction with decisions made are slightly more strongly correlated: the average correlation coefficient across domains is 0.38 for men and 0.32 for women. This means that, on average, individuals with higher autonomy are more satisfied with their decisions; however, the level of correlation is still relatively low.

On the other hand, the question of whether the respondent either makes a decision in the domain, or feels she could make a decision if she wished – which is an improvement on the standard decision-making questions that are often used to proxy empowerment – has low correlations for both men and women across all domains. In all but two cases correlations are 0.1 or under.

In summary, the two indicators that are slightly more correlated with individuals' relative autonomy, consistently across gender, are the domain-specific indicator of satisfaction with decisions made and the general indicator of satisfaction with 'power to make important decisions that change one's course of life', but even these correlation values are relatively low.

5.2 Regression Analysis

The correlation analysis provides only a rudimentary view of the relationship between different indicators, as it ignores both interactions between variables and non-linear relations. We use regression analysis to examine more formally the relationship between autonomy and other individual and household characteristics, and to investigate to what extent other indicators could be used as proxies for individual relative autonomy in Bangladesh.

5.2.1 Empirical Specification

We start by estimating the following equation:

$$RAI_{ij} = \beta_0 + \beta_1 X_i + \beta_2 F_i + \beta_3 H_i + \varepsilon_i, \quad (1)$$

where RAI_{ij} is individual i 's relative autonomy index in domain j , X_i is a vector of individual and household demographic characteristics (e.g. age, marital status, and number of household members), F_i is a vector of indicators of an individual's general functionings (e.g. years of schooling), H_i is a vector of indicators of housing quality and assets (e.g. improved sanitation, access to drinking water, ownership of assets), and ε_i is the error term. A list of the covariates and the respective descriptive statistics are included in the Appendix.

In a second round of regressions, we include an additional set of explanatory variables, Z_i (potential proxies for the RAI), to see how these are associated with autonomy, once we control for the individual and household's characteristics.

$$RAI_{ij} = \beta_0 + \beta_1 X_i + \beta_2 F_i + \beta_3 H_i + \beta_4 Z_i + \varepsilon_i \quad (2)$$

The summary statistics of all the variables used are presented in Table A.3 in the Appendix.

The equations are estimated separately for men and women,¹⁴ using a linear model,¹⁵ and take into account the complex survey design. Division dummies are included in all regressions to control for location-specific effects.¹⁶

5.2.2 Results

Estimates of Equation (1) for the RAI in domains of ‘agriculture production’, ‘livestock raising’, ‘non-farm business’, and ‘protection from violence’ are presented in Table 5. We selected these domains because they cover a broad spectrum of activities (including the main occupation of men and women in the sample) and allow us to illustrate our main conclusions.

Table 5: Estimates of Equation (1) using a Linear Regression Model

Variables	Domains							
	Agriculture production		Livestock raising		Non-farming business activity		Protection from violence	
	Men (1)	Women (2)	Men (3)	Women (4)	Men (5)	Women (6)	Men (7)	Women (8)
Age	0.008 (0.006)	0.007 (0.009)	0.009 (0.006)	0.001 (0.008)	-0.002 (0.008)	-0.001 (0.011)	0.001 (0.007)	0.013 (0.010)
Household head	0.205 (0.562)	0.070 (0.269)	-0.153 (0.470)	0.082 (0.245)	0.754 (0.545)	0.484 (0.398)	0.306 (0.561)	0.761*** (0.225)
No. of household members	0.096** (0.048)	0.026 (0.054)	0.057 (0.057)	-0.084 (0.056)	0.174*** (0.052)	0.033 (0.074)	0.093 (0.061)	-0.033 (0.066)
No. of members <6	0.198* (0.111)	0.196 (0.122)	0.262** (0.117)	0.114 (0.119)	-0.100 (0.129)	-0.416*** (0.130)	0.007 (0.140)	0.248 (0.151)
Years of education	-0.021 (0.020)	0.023 (0.026)	-0.038* (0.022)	-0.013 (0.024)	-0.038 (0.024)	0.008 (0.032)	-0.000 (0.021)	0.072** (0.030)
Occupation in agriculture	0.287 (0.596)	-0.719*** (0.185)	-0.033 (0.648)	-0.554*** (0.167)	0.651 (0.666)	-0.355* (0.211)	-0.227 (0.754)	-0.561** (0.222)
Sanitation	-0.539*** (0.192)	0.348* (0.186)	-0.258 (0.228)	0.460** (0.195)	-0.154 (0.236)	0.283 (0.232)	-1.053*** (0.289)	0.476* (0.245)
Cooking fuel	-1.054** (0.456)	-0.630 (0.422)	-0.087 (0.485)	-0.210 (0.398)	-1.161** (0.558)	-0.139 (0.578)	-0.417 (0.537)	-0.855 (0.547)
Assets – Access to information	0.411** (0.191)	0.235 (0.209)	0.120 (0.201)	0.141 (0.188)	0.319 (0.200)	0.520** (0.248)	0.036 (0.189)	0.181 (0.240)
Assets – Support to mobility	0.125 (0.155)	-0.176 (0.155)	0.148 (0.168)	0.045 (0.159)	-0.001 (0.175)	0.453** (0.193)	-0.039 (0.165)	0.389* (0.220)
Assets – Support to livelihood	0.230 (0.173)	0.169 (0.166)	0.658*** (0.241)	0.768*** (0.206)	-0.029 (0.177)	0.087 (0.208)	-0.145 (0.200)	0.400* (0.221)
Household expenditure p.c.	0.340*** (0.064)	0.028 (0.066)	0.323*** (0.071)	-0.025 (0.067)	0.306*** (0.069)	-0.013 (0.084)	0.471*** (0.082)	-0.174** (0.075)
Barisal	-1.219** (0.580)	0.506 (0.827)	-1.124** (0.570)	-3.060*** (0.690)	-1.806*** (0.610)	0.500 (0.945)	-1.355** (0.528)	0.660 (0.573)
Chittagong	-0.054 (0.511)	-1.210*** (0.395)	0.159 (0.516)	-1.786*** (0.461)	0.029 (0.450)	-1.283** (0.531)	-0.235 (0.620)	-2.507*** (0.431)
Khulna	1.210*** (0.385)	1.023*** (0.354)	1.429*** (0.381)	0.130 (0.342)	1.480*** (0.386)	1.374*** (0.448)	0.428 (0.407)	-0.146 (0.431)
Rajshahi	-1.775*** (0.580)	-0.768 (0.827)	-1.856*** (0.570)	-2.231*** (0.690)	-2.542*** (0.610)	-1.295* (0.945)	-3.420*** (0.528)	-1.342* (0.573)

¹⁴ Otherwise, as there is a male and female from each household, the errors are likely to be correlated.

¹⁵ The Relative Autonomy Index (RAI) is a Likert Scale. So, it can be analysed as an interval scale (Allen and Seaman, 2007; Brown, 2011; Carifio and Perla, 2007).

¹⁶ We also estimated the equations using an ordered probit model as a robustness check. The conclusions did not change. These estimates are included in the Appendix.

	(0.481)	(0.638)	(0.503)	(0.601)	(0.501)	(0.702)	(0.409)	(0.740)
Rangpur	-2.696***	-1.333***	-2.274***	-2.460***	-2.969***	-2.013***	-3.206***	-3.348***
	(0.375)	(0.358)	(0.452)	(0.354)	(0.419)	(0.432)	(0.378)	(0.335)
Sylhet	0.045	-0.994**	0.135	-1.237**	-0.375	-1.471**	-2.178***	0.430
	(0.411)	(0.504)	(0.390)	(0.546)	(0.429)	(0.655)	(0.569)	(0.431)
constant	2.201***	3.642***	2.092***	4.837***	3.293***	3.643***	1.689**	4.932***
	(0.528)	(0.680)	(0.656)	(0.627)	(0.618)	(1.179)	(0.721)	(0.738)
F-statistic	12.9***	5.7***	8.0***	7.1***	9.8***	9.3***	19.2***	14.9***
R-squared	0.177	0.078	0.165	0.131	0.205	0.132	0.260	0.201
No. of observations	2,882	2,636	2,809	3,231	2,222	1,607	1,660	1,524

Note: The table does not include the estimates of explanatory variables that are not significant in any of the regressions presented, namely: occupation of household head, nutrition and drinking water. *** p<0.01, ** p<0.05, * p<0.1

Three general features become apparent when we look at these tables. First, men's and women's relative autonomy seems to be determined by different factors. Second, geographical location, which may proxy different cultural norms in each of Bangladesh's divisions, affects the autonomy of both men and women. Third, the factors that determine relative autonomy vary across domains of decision-making.

Differences across gender. Men's autonomy is positively associated with income. The coefficient of the quintile of per capita expenditure is significant in all regressions of men's RAI. On the other hand, this coefficient is not significant in any of the regressions of women's RAI, except in 'protection from violence', where the coefficient is negative. The negative sign on protection from violence, however, highlights the possibility that domestic violence (which is likely to be the form of violence to which women are more exposed in Bangladesh) does not decrease with income.

Women's relative autonomy, on the other hand, is associated with their occupation and sector of work. The results suggest that women engaged in activities related to agriculture tend to have lower levels of autonomy than women engaged in other activities. This relationship is significant at the 1% level in all domains, except 'non-farming business activity'. The occupation of most women in rural Bangladesh is either livestock/poultry raising (50% of the sample) – here classified as related to agriculture – or housewife (42%). So, housewives seem to have higher autonomy than other women, possibly because they may have greater decision-making power within the domestic sphere, compared to agriculture where men typically make most of the decisions.

Less important, but intriguing, we find that sanitation tends to be negatively associated with men's autonomy, but positively associated with women's RAI. It is possible that having better sanitary facilities on one's homestead reduces women's vulnerability in terms of having to use facilities outside, but this effect does not hold for men.¹⁷ Another possible explanation is that improved sanitation might reduce the

¹⁷ Indeed, in some parts of South Asia, having the husband assure that the home to which a bride is moving has its own toilet has become a condition for marriage.

number of illness episodes in the household and be associated with easier access to water, reducing women's unpaid care and domestic work.

Geographical location. The high significance of the location dummies suggests that, after controlling for income distribution, basic housing conditions, and individuals' characteristics, there are (unobservable) local factors that have a strong effect on individuals' autonomy. However, as location dummies capture differences in social norms and economic conditions that may have offsetting effects, these coefficients need to be interpreted carefully.

Determinants of autonomy in specific domains. The pattern of determinants of women's autonomy in the domain of 'protection from violence' is particularly interesting. Women's education is not significantly associated with autonomy in any other domain, except for this. This is an important result, given the high rates of intimate partner violence in Bangladesh: increasing women's education thus continues to be an important policy priority for women's overall empowerment and welfare.¹⁸ Being the household head is also associated with women's autonomy only in this domain, possibly because being a female head of household often results from widowhood or divorce, and implies the absence of a husband and in-laws who might perpetuate domestic violence.

It is noteworthy that ownership of specific assets affect women's autonomy in different domains. For instance, assets related to access to information and support to mobility seem to have a positive impact on women's autonomy in the domain of 'non-farming business activity'. Assets to support livelihoods also have a positive impact on women's autonomy in protection from violence, which is consistent with findings from India that asset ownership is protective against domestic violence (Panda and Agarwal 2005). In contrast to income, assets, particularly those related to information, mobility, and livelihoods, thus appear to have a positive impact on women's autonomy. These results are potentially relevant to programs that seek to increase women's control of assets.

The set of variables that are significantly correlated with the RAI varies across domains. This evidence supports the hypothesis that autonomy is domain-specific and, therefore, it should be measured separately in different domains.

The analysis above has shown that neither age, education, nor income are suitable proxies for relative autonomy of men and women. Now we investigate if the indicators on decision-making are valid candidates.

¹⁸ Unfortunately, we do not have information on the 'forms' that violence takes. For instance, withdrawal of financial support and physical abuse are very distinct forms of violence and most likely have different implications for autonomy.

Table 6.1: Estimates of Equation (2) using Linear Model – Sample of Men

Variables	Domains								
	Agriculture production			Non-farming business activity			Protection from violence		
	(1)	(2)	(3)	(4)	(5)	(6)	(7)	(8)	(9)
Age	0.009 (0.006)	0.009 (0.006)	0.008 (0.006)	-0.001 (0.008)	0.003 (0.007)	-0.001 (0.007)	0.002 (0.007)	0.003 (0.007)	0.002 (0.007)
Household head	-0.005 (0.559)	-0.037 (0.538)	0.005 (0.560)	0.684 (0.550)	0.453 (0.485)	0.688 (0.561)	0.317 (0.558)	0.094 (0.587)	0.393 (0.558)
No. of hh members	0.100** (0.048)	0.043 (0.049)	0.080* (0.048)	0.176*** (0.052)	0.131*** (0.047)	0.156*** (0.053)	0.092 (0.061)	0.078 (0.055)	0.078 (0.059)
No. of members <6	0.197* (0.112)	0.185* (0.105)	0.197* (0.110)	-0.100 (0.129)	-0.111 (0.128)	-0.083 (0.128)	0.005 (0.140)	0.011 (0.126)	0.017 (0.141)
Years of education	-0.022 (0.020)	-0.021 (0.018)	-0.032* (0.019)	-0.038 (0.024)	-0.026 (0.021)	-0.045* (0.023)	0.000 (0.021)	0.002 (0.021)	-0.005 (0.021)
Occupation in agriculture	0.186 (0.589)	0.304 (0.563)	0.277 (0.576)	0.666 (0.679)	0.420 (0.588)	0.829 (0.688)	-0.224 (0.756)	-0.262 (0.736)	-0.276 (0.760)
Sanitation	-0.547*** (0.192)	-0.533*** (0.184)	-0.615*** (0.191)	-0.153 (0.237)	-0.384* (0.222)	-0.243 (0.233)	-1.054*** (0.289)	-1.046*** (0.280)	-1.104*** (0.285)
Cooking fuel	-1.049** (0.456)	-1.020** (0.462)	-0.993** (0.443)	-1.153** (0.556)	-0.916* (0.532)	-1.079** (0.547)	-0.424 (0.539)	-0.459 (0.511)	-0.409 (0.562)
Assets – Access to information	0.421** (0.191)	0.399** (0.187)	0.393** (0.189)	0.313 (0.199)	0.233 (0.194)	0.278 (0.198)	0.036 (0.189)	0.033 (0.190)	0.034 (0.187)
Assets – Support to mobility	0.105 (0.156)	0.072 (0.149)	0.073 (0.151)	-0.008 (0.176)	-0.129 (0.161)	-0.016 (0.171)	-0.038 (0.165)	-0.130 (0.162)	-0.059 (0.163)
Assets – Support to livelihood	0.234 (0.172)	0.217 (0.155)	0.219 (0.169)	-0.024 (0.177)	-0.005 (0.158)	-0.090 (0.172)	-0.143 (0.200)	-0.216 (0.193)	-0.183 (0.198)
HH expenditure p.c.	0.341*** (0.064)	0.228*** (0.061)	0.296*** (0.062)	0.302*** (0.070)	0.202*** (0.064)	0.257*** (0.070)	0.469*** (0.081)	0.420*** (0.078)	0.445*** (0.080)
Barisal	-1.262** (0.581)	-1.476*** (0.563)	-1.304** (0.544)	-1.826*** (0.612)	-2.076*** (0.604)	-1.902*** (0.564)	-1.346** (0.534)	-1.552*** (0.537)	-1.399*** (0.517)
Chittagong	-0.100 (0.512)	-0.057 (0.465)	-0.087 (0.501)	0.006 (0.452)	0.003 (0.401)	-0.005 (0.444)	-0.232 (0.621)	-0.273 (0.570)	-0.151 (0.620)
Khulna	1.204*** (0.388)	0.971** (0.388)	1.059*** (0.376)	1.470*** (0.387)	1.101*** (0.370)	1.332*** (0.375)	0.424 (0.407)	0.472 (0.398)	0.399 (0.406)
Rajshahi	-1.708*** (0.469)	-0.938** (0.444)	-1.546*** (0.461)	-2.540*** (0.502)	-1.755*** (0.452)	-2.323*** (0.493)	-3.423*** (0.404)	-2.744*** (0.400)	-3.313*** (0.411)
Rangpur	-2.698*** (0.373)	-2.263*** (0.355)	-2.457*** (0.390)	-2.959*** (0.421)	-2.223*** (0.368)	-2.716*** (0.431)	-3.204*** (0.378)	-2.508*** (0.377)	-3.100*** (0.385)
Sylhet	0.027 (0.408)	0.172 (0.365)	0.351 (0.397)	-0.398 (0.428)	-0.266 (0.374)	0.003 (0.433)	-2.179*** (0.568)	-1.475*** (0.535)	-1.904*** (0.580)
Feel can make decisions	0.659** (0.282)	0.391 (0.297)	0.592** (0.282)	0.342 (0.290)	0.234 (0.264)	0.296 (0.280)	-0.059 (0.237)	-0.104 (0.230)	-0.072 (0.238)
Satisfaction with decisions		1.096*** (0.124)			1.293*** (0.128)			0.949*** (0.147)	
Power to make decisions			0.247*** (0.046)			0.284*** (0.051)			0.146** (0.061)
Constant	1.791*** (0.541)	-1.991*** (0.698)	0.608 (0.572)	3.069*** (0.638)	-2.063*** (0.745)	1.608** (0.675)	1.726** (0.710)	-1.799** (0.817)	0.921 (0.764)
F-statistic	13.06***	17.05***	13.60***	9.42***	21.53***	12.43***	18.67***	24.41***	18.10***
R-squared	0.180	0.248	0.199	0.205	0.288	0.227	0.260	0.309	0.266
No. of observations	2,882	2,876	2,882	2,222	2,215	2,222	1,660	1,643	1,660

Note: The table does not include the estimates of explanatory variables that are not significant in any of the regressions presented, namely: occupation of household head, nutrition, and drinking water. *** p<0.01, ** p<0.05, * p<0.1

Table 6.2: Estimates of Equation (2) using Linear Model – Sample of Women

Variables	Domains								
	Agriculture production			Non-farming business activity			Protection from violence		
	(1)	(2)	(3)	(4)	(5)	(6)	(7)	(8)	(9)
Age	0.007 (0.009)	0.000 (0.008)	0.003 (0.008)	-0.000 (0.010)	-0.002 (0.010)	-0.003 (0.010)	0.013 (0.010)	0.006 (0.010)	0.010 (0.010)
Household head	-0.033 (0.274)	-0.117 (0.276)	-0.057 (0.277)	0.394 (0.402)	0.321 (0.419)	0.372 (0.412)	0.733*** (0.221)	0.678*** (0.234)	0.714*** (0.226)
No. of household members	0.020 (0.054)	0.021 (0.050)	0.021 (0.053)	0.030 (0.074)	0.012 (0.068)	0.023 (0.075)	-0.035 (0.065)	-0.079 (0.061)	-0.039 (0.067)
No. of members <6	0.204* (0.122)	0.194* (0.116)	0.145 (0.117)	-0.409*** (0.130)	-0.379*** (0.131)	-0.431*** (0.131)	0.255* (0.150)	0.226 (0.152)	0.233 (0.145)
Years of education	0.022 (0.026)	0.011 (0.025)	0.014 (0.025)	0.010 (0.032)	-0.018 (0.033)	0.006 (0.031)	0.071** (0.030)	0.061** (0.031)	0.066** (0.029)
Occupation in agriculture	-0.730*** (0.185)	-0.787*** (0.182)	-0.657*** (0.183)	-0.366* (0.210)	-0.407* (0.209)	-0.342* (0.206)	-0.568** (0.222)	-0.517** (0.217)	-0.572** (0.222)
Sanitation	0.356* (0.186)	0.222 (0.181)	0.309 (0.188)	0.305 (0.234)	0.271 (0.235)	0.272 (0.232)	0.478* (0.246)	0.386 (0.249)	0.463* (0.243)
Cooking fuel	-0.645 (0.420)	-0.451 (0.376)	-0.652 (0.423)	-0.169 (0.576)	0.160 (0.537)	-0.198 (0.566)	-0.850 (0.546)	-0.548 (0.502)	-0.848 (0.550)
Assets – Access to information	0.242 (0.208)	0.097 (0.210)	0.215 (0.204)	0.498** (0.246)	0.472* (0.245)	0.505** (0.240)	0.181 (0.240)	0.103 (0.239)	0.169 (0.241)
Assets – Support to mobility	-0.166 (0.156)	-0.256* (0.148)	-0.136 (0.151)	0.458** (0.192)	0.257 (0.192)	0.439** (0.188)	0.397* (0.222)	0.366* (0.209)	0.422* (0.219)
Assets – Support to livelihood	0.168 (0.165)	0.073 (0.159)	0.154 (0.161)	0.069 (0.207)	0.070 (0.212)	0.025 (0.205)	0.408* (0.221)	0.421* (0.226)	0.381* (0.217)
Household expenditure p.c.	0.022 (0.067)	0.003 (0.065)	-0.041 (0.067)	-0.020 (0.083)	-0.056 (0.082)	-0.069 (0.085)	-0.174** (0.075)	-0.173** (0.076)	-0.199*** (0.077)
Barisal	0.530 (0.828)	0.447 (0.774)	0.639 (0.820)	0.441 (0.946)	0.415 (0.868)	0.575 (0.945)	0.636 (0.576)	-0.106 (0.540)	0.619 (0.566)
Chittagong	-1.155*** (0.402)	-1.339*** (0.412)	-1.103*** (0.396)	-1.233** (0.536)	-1.390** (0.565)	-1.179** (0.536)	-2.486*** (0.429)	-2.801*** (0.416)	-2.393*** (0.419)
Khulna	1.036*** (0.353)	0.780** (0.340)	1.025*** (0.335)	1.335*** (0.445)	1.078** (0.438)	1.340*** (0.447)	-0.180 (0.432)	-0.745** (0.348)	-0.208 (0.453)
Rajshahi	-0.771 (0.635)	-0.716 (0.566)	-0.805 (0.587)	-1.302* (0.692)	-1.221** (0.622)	-1.271* (0.679)	-1.350* (0.739)	-1.682*** (0.591)	-1.394* (0.713)
Rangpur	-1.291*** (0.362)	-1.196*** (0.357)	-1.301*** (0.356)	-1.966*** (0.437)	-1.754*** (0.421)	-1.940*** (0.437)	-3.338*** (0.340)	-3.042*** (0.392)	-3.367*** (0.346)
Sylhet	-0.924* (0.511)	-0.847* (0.460)	-0.767 (0.494)	-1.470** (0.666)	-1.433** (0.624)	-1.309** (0.665)	0.406 (0.432)	0.076 (0.390)	0.439 (0.440)
Feel can make decisions	0.316** (0.159)	0.132 (0.151)	0.168 (0.155)	0.362* (0.185)	0.153 (0.190)	0.298 (0.185)	0.136 (0.195)	-0.070 (0.202)	0.108 (0.197)
Satisfaction with decisions		1.090*** (0.117)			1.097*** (0.160)			1.391*** (0.150)	
Power to make decisions			0.235*** (0.044)			0.154*** (0.054)			0.119** (0.060)
Constant	3.478*** (0.692)	-0.290 (0.835)	2.605*** (0.728)	3.427*** (1.185)	-0.757 (1.445)	2.820** (1.260)	4.866*** (0.756)	-0.488 (1.024)	4.487*** (0.810)
F-statistic	6.03***	11.64***	8.42***	9.57***	16.20***	9.52***	14.13***	18.52***	12.33***
R-squared	0.080	0.139	0.102	0.135	0.189	0.144	0.201	0.281	0.208
No. of observations	2,636	2,562	2,636	1,607	1,509	1,607	1,523	1,417	1,523

Note: The table does not include the estimates of explanatory variables that are not significant in any of the regressions presented, namely: occupation of household head, nutrition, and drinking water. *** p<0.01, ** p<0.05, * p<0.1

Tables 6.1 (sample of men) and 6.2 (sample of women) present the estimates of Equation (2) for the RAI in the same domains considered above, except 'livestock raising'. For each domain-specific RAI we present three sets of results, where we examine the sensitivity of adding the following explanatory variables:

- (i) The domain-specific indicator ‘feel can make decision’;
- (ii) The domain-specific indicators ‘feel can make decisions’ and ‘satisfaction with decisions made’; and
- (iii) The domain-specific indicator ‘feel can make decisions’ and the general indicator ‘power to make important decisions’.

The indicator ‘feel can make a decision’ is only significantly associated with the RAI in some domains. So, as suggested by the correlation analysis, this indicator is not a good candidate to proxy autonomy.

The indicators ‘satisfaction with decisions made’ and ‘power to make important decisions’, on the other hand, are significantly associated with higher levels of autonomy of men and women in all domains. Nevertheless, they still do not account for a large portion of the variation, which is indicated by the low magnitude of the R-squared and the fact that in most cases their inclusion as explanatory variables does not affect the significance of the other determinants of autonomy (except for the variable ‘feel can make the decisions’). Under these circumstances, it remains unclear whether these indicators can be used as proxies for autonomy, or are simply indicators that are also correlated with autonomy.

The indicators ‘satisfaction with decisions made’ and ‘power to make important decisions’, on the other hand, are significantly associated with higher levels of autonomy of men and women in all domains. Nevertheless, they still do not account for a large portion of the variation, which is indicated by the low magnitude of the R-squared and the fact that in most cases their inclusion as explanatory variables does not affect the significance of the other determinants of autonomy (except for the variable ‘feel can make the decisions’). Under these circumstances, it remains unclear whether these indicators can be used as proxies for autonomy, or are simply indicators that are also correlated with autonomy.

6. Conclusion

This paper provides a detailed examination of the Relative Autonomy Index using data representative of Bangladeshi rural areas. We report mixed but largely positive results in terms of the conceptual validity of the RAI. We find evidence of three dimensions in the data, each one corresponding to one of the motivation subscales, exactly as predicted by the measurement model. The surprise is that we do not always find an ordered correlation among the three motivation subscales as expected by the self-determination continuum. Instead, we find gendered patterns of correlations. In the sample of men, we find that external and introjected motivations are strongly correlated, and both are weakly correlated with autonomous motivations, as predicted by the RAI measurement model. In the sample of women, we find that external motivation is positively and strongly correlated with introjected and autonomous motivations, yet the correlations between introjected and autonomous motivations tend to be weak. We speculate that

the strong correlation between external and autonomous motivation arises because Bangladeshi women internalize societal norms and ‘make them their own’, but qualitative work is needed to study this issue.

Our exploratory analysis of the determinants of autonomy of men and women in Bangladesh shows that neither age nor education nor income are suitable proxies for autonomy. We also find no robust evidence that other indicators of decision-making adequately proxy autonomy.

The search for rigorous, transparent, and domain-specific measures of empowerment that can be used for gendered analysis is ongoing. Many indicators have failed to fulfil the criteria required for rigorous quantitative analyses of women’s empowerment. This paper demonstrates that the RAI as implemented in Bangladesh is a reliable indicator of autonomy and adds value and information to variables such as education, expenditure, age, mobility, and decision-making. It distinguishes male from female autonomy and differentiates autonomy levels across different domains. As such, the RAI very much remains a strong candidate for empirical studies of empowerment. To further advance this field, it is necessary both to explore qualitatively what appear to be cultural influences on women’s external motivation in Bangladesh and to implement the RAI in additional geographic and cultural settings to explore its validity and reliability in those settings.

References

- Abell, N., Springer, D. W., and Kamata, A. (2009). *Developing and Validating Rapid Assessment Instruments*. New York: Oxford University Press.
- Alkire, S. (2005). 'Subjective quantitative studies of human agency,' *Social Indicators Research*, 74(1), pp. 217–260.
- Alkire, S. (2008). 'Concepts and Measures of Agency', In: K. Basu and R. Kanbur (Eds.), *Arguments for a Better World: Essays in Honour of Amartya Sen*, ch. 24. Oxford: Oxford University Press.
- Alkire, S., Meinzen-Dick, R., Peterman, A., Quisumbing, A., Seymour, G., and Vaz, A. (2013). 'The women's empowerment in agriculture index', *World Development*, 52, pp. 71–91.
- Allen, E. and Seaman, C. (2007). 'Likert scales and data analyses', *Quality Progress*, 40, pp. 646–5.
- Alsop, R., Bertelsen, M. F., and Holland, J. (2006). *Empowerment in Practice: From Analysis to Implementation*. Washington DC: World Bank.
- Becker, E. (2012). *Themes from Feed the Future Women's Empowerment in Agriculture Index: Report from Qualitative Case Studies in Bangladesh, Guatemala and Uganda*. Unpublished report submitted to the International Food Policy Research Institute, Washington, DC.
- Brown, J. (2011). 'Likert items and scales of measurement', *Shiken: JALT Testing and Evaluation SIG Newsletter*, 15(1), pp. 10–14.
- Carifio, J. and Perla, R. (2007). 'Ten common misunderstandings, misconceptions, persistent myths and urban legends about Likert scales and Likert response formats and their antidotes', *Journal of Social Sciences*, 3(3), pp. 106–116.
- Chirkov, V. I., Ryan, R., Kim, Y., and Kaplan, U. (2003). 'Differentiating autonomy from individualism and independence: A self-determination theory perspective on internalization of cultural orientations and well-being', *Journal of Personality and Social Psychology*, 84(1), pp. 97–110.
- Chirkov, V. I. (2009). 'A cross-cultural analysis of autonomy in education: A self-determination theory perspective', *Theory and Research in Education*, 7, pp. 253–262.
- Chirkov, V. I., Ryan, R. M., and Sheldon, K. M. (2011). *Human Autonomy in Cross-cultural Contexts: Perspectives on the Psychology of Agency, Freedom, and Well-being*, Dordrecht: Springer.
- Cortina, J. M. (1993). 'What is coefficient alpha? An examination of theory and applications', *Journal of Applied Psychology*, 78(1), pp. 98–104.
- Deci, E. L., and Ryan, R. M. (2012). 'Motivation, personality, and development within embedded social contexts: An overview of self-determination theory', In R. M. Ryan (Ed.), *Oxford Handbook of Human Motivation* (pp. 85–107). Oxford: Oxford University Press.
- Drèze, J. and Sen, A. (2013). *An Uncertain Glory: India and its Contradictions*, Princeton; Oxford: Princeton University Press.
- Guio, A.-C., Gordon, D., and Marlier, E. (2012). 'Measuring material deprivation in the EU: Indicators for the whole population and child-specific indicators', Eurostat Methodologies and Working Paper, Publications Office of the European Union, Luxembourg, available [here](#).

- Hemker, B. T., Sijtsma, K., and Molenaar, I. W. (1995). 'Selection of unidimensional scales from a multidimensional item bank in the polytomous Mokken IRT model', *Applied Psychological Measurement*, 19(4), pp. 337–352.
- Ibrahim, S. and Alkire, S. (2007). 'Agency and empowerment: A proposal for internationally comparable indicator', *Oxford Development Studies*, 35(4), pp. 405–430.
- Kabeer, N. (2001). 'Ideas, economics, and the sociology of supply: Explanations for fertility decline in Bangladesh', *Journal of Development Studies*, 38(1), pp. 29–70.
- Kishor, S., and Subaiya, L. (2008). *Understanding Women's Empowerment: A Comparative Analysis of Demographic and Health Surveys (DHS) Data*. DHS Comparative Reports 20. Calverton, MD: Macro International.
- Levesque, C. S., Williams, G. C., Elliot, D., Pickering, M. A., Bodenhamer, B., and Finley, P. J. (2007). 'Validating the theoretical structure of the Treatment Self-Regulation Questionnaire (TSRQ) across three different health behaviors', *Health Education Research*, 22(5), pp. 691–702.
- Malhotra, A., Schuler, S., and Boender, C. (2002). *Measuring Women's Empowerment as a Variable in International Development*. Gender and Development Group. Washington, DC: World Bank.
- Narayan, D. (2005). 'Conceptual framework and methodological challenges', In: D. Narayan (Ed.), *Measuring Empowerment: Cross Disciplinary Perspectives*. Washington, DC: World Bank.
- Nazneen, S., N. Hossain, and M. Sultan. (2011). 'National discourses on women's empowerment in Bangladesh: Continuities and change', IDS Working Paper 368, Brighton, UK: Institute of Development Studies.
- Panda, P. and Agarwal, B. (2005). 'Marital violence, human development and women's property status in India', *World Development*, 33(5), pp. 823–850.
- Ryan, R. M. and Connell, J. P. (1989). 'Perceived locus of causality and internalization: Examining reasons for acting in two domains', *Journal of Personality and Social Psychology*, 57, pp. 749–761.
- Ryan, R. M. and Deci, E. L. (2000). 'Self-determination theory and the facilitation of intrinsic motivation, social development, and well-being', *American Psychologist*, 55(1), pp. 68–78.
- Samman, E. and Santos, M. E. (2009). 'Agency and empowerment: A review of concepts, indicators and empirical evidence', OPHI Research in Progress 10a, University of Oxford.
- Sraboni, E., Quisumbing, A. R., and Ahmed, A. U. (2013). *The Women's Empowerment in Agriculture Index: Results from the 2011-2012 Bangladesh Integrated Household Survey*. Project report submitted to the U.S. Agency for International Development. International Food Policy Research Institute, Dhaka. Available [here](#).
- Sraboni, E., Malapit, H., Quisumbing, A. R., and Ahmed, A. U. (2013). 'Women's empowerment in agriculture: What role for food security in Bangladesh', ICAS VI Sixth International Conference in Agricultural Statistics. Unpublished conference paper.
- Vaz, A., Pratley, P., and Alkire, S. (2016). 'Measuring women's autonomy in Chad using the relative autonomy index', *Feminist Economics*, 22(1), pp. 264–294.
- World Bank. (2005). *Maintaining Momentum to 2015? An Impact Evaluation of Interventions to Improve Maternal and Child Health and Nutrition in Bangladesh*. Washington, DC: The World Bank.

Appendix

This information is organized under the corresponding headings in the paper.

2. Conceptual Framework

Figure A.1 summarizes the conceptual definitions

Figure A.1: The Self-Determination Continuum

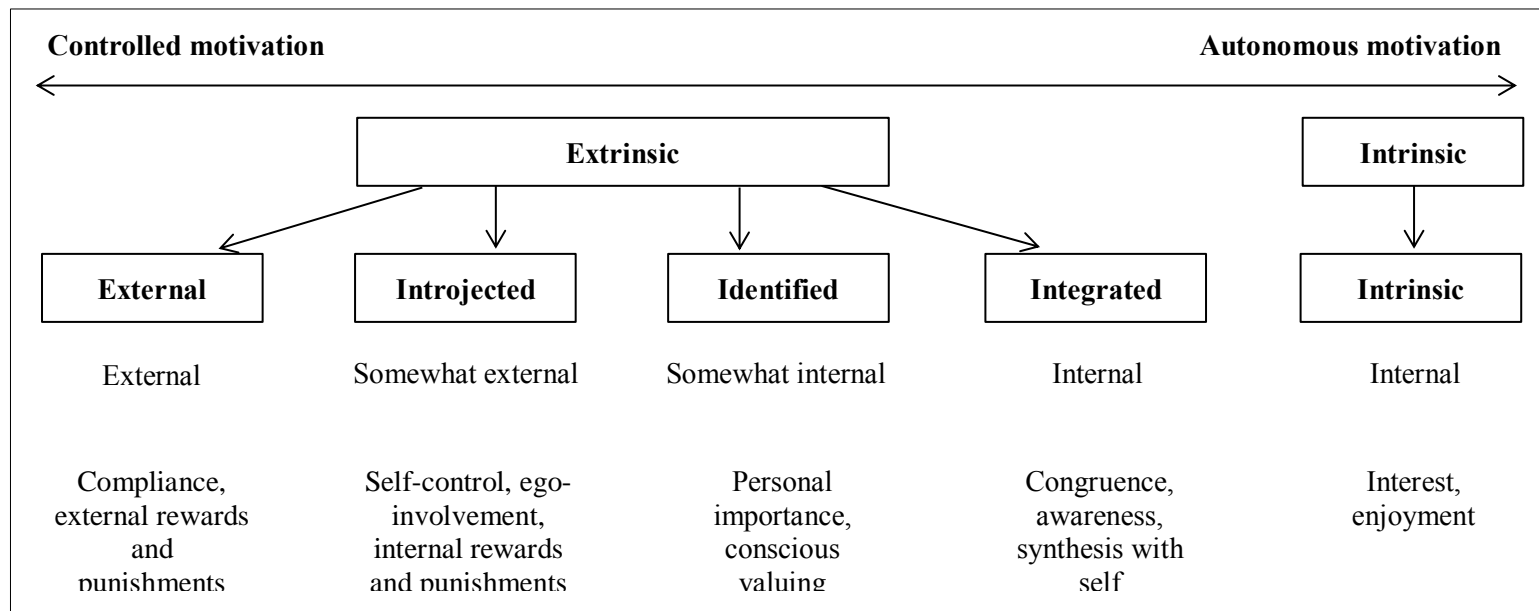

Note: Based on Ryan and Deci, 2000.

4. Conceptual Validity and Reliability

4.1 Conceptual Validity

4.2.1 Dimensional Structure

Exploratory Factor Analysis

We started by performing an Exploratory Factor Analysis (EFA) to investigate if a three-factor solution that discriminates the items of the three motivation subscales emerges. We estimated the polychoric correlation matrix considering the sampling weights and perform the factor analysis using that matrix. To facilitate the interpretation of the factor loadings we rotated the axes. We used oblique rotation, given that the motivation subscales are likely to be correlated.

First, we considered the full set of items. Probably due to the large number of variables combined with the small size of the sample (there are only 636 individuals who answered the motivation questions for all 13 areas of decision-making), the solution obtained is a Heywood case.¹⁹

Second, we selected a more similar subset of domains of decision-making, in which we expected the motivations to be more correlated. We performed an EFA considering only the areas of decision-making related to agriculture, namely the domains ‘agriculture production’, ‘what inputs to buy’, ‘what crops to grow’, and ‘who and when to take the crops to the market’. The sample under analysis increased from 636 to 4,910 individuals. Considering Kaiser’s eigenvalue-greater-than-one rule, the expected three-factor structure emerged.²⁰ As shown in Table A.1, we find that the set of questions that are supposed to measure different subscales are clearly discriminated in different factors. Factors capturing external and introjected subscales are strongly correlated. However, contrary to the theory, the factor capturing the autonomous subscale is much more correlated with the external factor than with the factor capturing the introjected subscale. We obtain similar results if we consider the set of decision-making domains not related to economic activities.²¹

¹⁹ Using a Pearson correlation matrix instead of the polychoric correlation, the solution obtained is not a Heywood case. In this solution, according to the Kaiser criterion, there are four factors in the data. In the four-factor solution, we find that the factors 1 and 2 discriminate the questions from the subscales external and autonomous, respectively. Factors 3 and 4 cover the introjected subscale, with factor 3 including seven of the 13 questions and factor 4, six.

²⁰ An alternative criterion would be the parallel analysis. This procedure proposes retaining all factors with an eigenvalue higher than the eigenvalue obtained from a randomly generated dataset with the same number of variables and observations. Using this criterion we would keep all factors. However, only the first three factors have items with a loading higher than 0.3.

²¹ We considered the following domains as unrelated to economic activities: minor household expenditures, what to do if you have a serious health problem, how to protect yourself from violence, whether and how to express religious faith, what kind of tasks you will do on a particular day, and whether or not to use family planning to space or limit births.

Table A.1: Results of EFA considering questions related to agriculture

	Sample of men and women			
	Factor1	Factor2	Factor3	
Proportion of variance explained⁽¹⁾	41%	37%	36%	
Factor loadings⁽²⁾				
Variable	Factor1	Factor2	Factor3	Uniqueness
External - Agricultural production	0.9659			0.0729
External - Inputs	0.9582			0.0741
External - Crops	0.9531			0.0774
External - Take crops to markets	0.9081			0.1546
Introjected - Agricultural production			0.8917	0.2070
Introjected - Inputs			0.8934	0.1982
Introjected - Crops			0.8854	0.2078
Introjected - Take crops to markets			0.8225	0.2880
Autonomous - Agricultural production		0.9674		0.0561
Autonomous - Inputs		0.9792		0.0398
Autonomous - Crops		0.9707		0.0570
Autonomous - Take crops to markets		0.9565		0.0925
Correlation matrix of the rotate common factors⁽³⁾				
	Factor 1	Factor 3	Factor 2	
External	1			
Introjected	0.430	1		
Autonomous	0.191	0.005	1	

⁽¹⁾ Rotated factors are correlated

⁽²⁾ Blanks represent loading below 0.3

⁽³⁾ The order of the factors was changed to replicate the self-determination continuum.

Multiple Correspondence Analysis

Women's empowerment is known to be multidimensional, with empowerment in one domain such as family not necessarily implying empowerment in another, such as workplace. In the case of the agricultural domains, one might suspect that similar levels of empowerment might be associated with each domain, because they each relate to economic productivity. To explore this further, as well as to further elucidate the relationship among the variables, treating them now as purely categorical, we examined the data structure using a Multiple Correspondence Analysis (MCA). This descriptive method can be seen as a generalization of the principle component analysis to categorical data. In very simple terms, this technique divides each categorical variable into dummy variables that represent the categories of the original variable and describes the pattern of the dataset geometrically by locating each of these 'new' dummy variables in a low-dimensional space.

We performed multiple correspondence analysis using the questions related to agriculture (a smaller set of variables and larger sample of individuals). We performed this analysis separately by gender. In the case of men, we found that three motivations explain 71% of the inertia.²² The first dimension explains 28.7%; the second, 26.5%; and the third, 15.3%.²³ Similarly for women, the percentages of inertia explained by each dimension are: 27.7%, 25.6%, and 12.0%. Figure A.2 plots the point coordinates of items related to ‘what inputs to buy’ and ‘what crops to grow’ in dimensions 1 and 2. We did not include items regarding the other two agricultural domains because they tend to overlap, making the reading of the graphic difficult. Thus, we see a similar motivational structure across the agricultural domains by gender.

Figure A.2: Plot of MCA, questions regarding what inputs to buy and what crops to grow

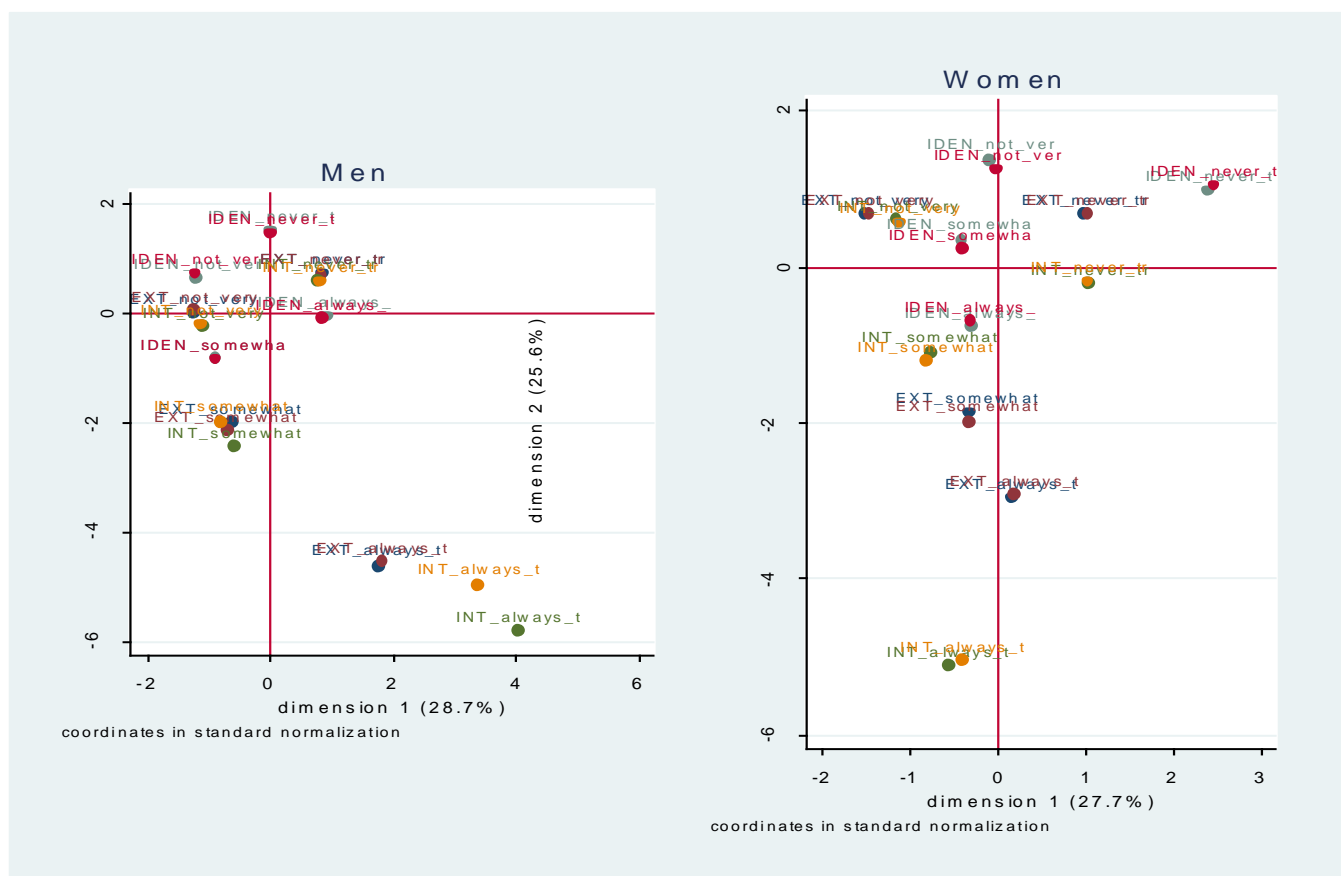

Cluster Analysis

Finally, we examined if a cluster analysis groups the motivation questions according to the type of motivation they are intended to measure. We performed the analysis separately by gender. We computed a proximity matrix based on the squared Euclidean Distance. Then clusters were produced using the

²² The concept of inertia in multiple correspondence analysis is equivalent to variance in factor analysis (Abdi and Valentim, 2007).

²³ The fourth dimension already only explains 8.7% of the inertia.

hierarchical average linkage method.²⁴ We performed this analysis considering the full set of domains initially. The resulting dendrograms are presented in Figure A.3. Second, to be able to draw conclusions based on a larger sample, we conducted a new cluster analysis focusing only on the domains related to agriculture. The respective dendrograms are presented in Figure A.4.

Figure A.4: Dendrograms, considering agricultural domains

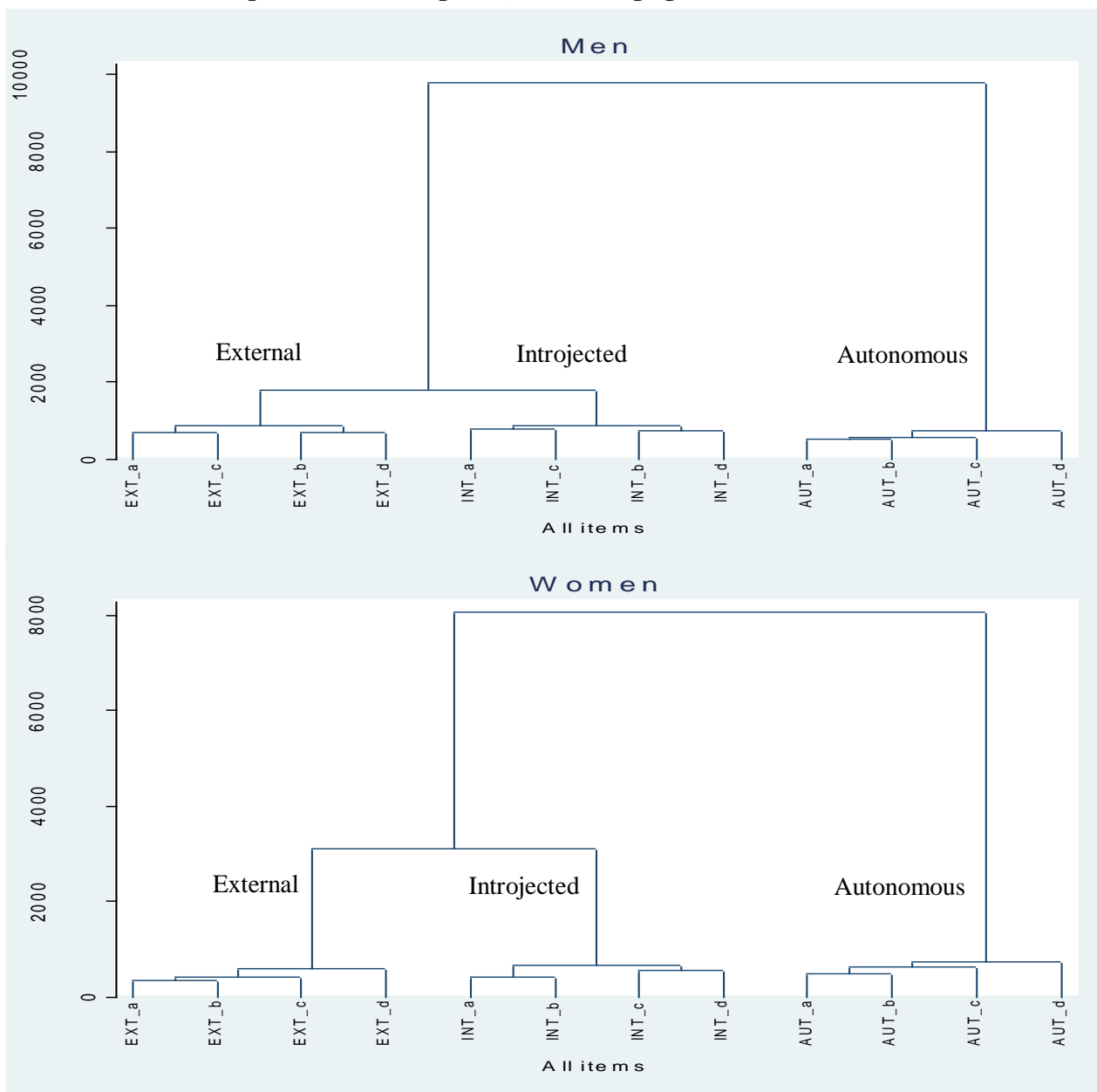

Note: In the names of the items 'EXT' identifies the external motivation questions, 'INT' identifies the introjected motivation questions, and 'AUT' refers to autonomous motivation questions. The letters identify the domains.

²⁴ The cluster analysis was also conducted considering alternative linkage methods, namely, complete linkage and Ward's method. The same structure was identified using the different methods.

Men

Let's focus first on the case of men. The dendrogram in Figure A.3 suggests that there are two broad clusters that distinguish controlled and autonomous motivations. This two-cluster structure is corroborated by the Calinski-Harabasz stopping rule. According to the Duda-Hart stopping rule, there are five clusters. According to this rule, the autonomous motivation questions are all grouped in the same cluster. The external and introjected questions are divided in two different clusters each. Under this structure, controlled and autonomous motivations are clearly separated, but some external questions are closer to some introjected questions than to other external questions. So the two-cluster controlled-autonomous structure is validated by Calinski-Harabasz, and the three categories are verified by Duda-Hart, but the external and introjected are interspersed to make five categories.

When considering a more restricted set of domains, the results are similar. The Calinski-Harabasz stopping rule suggests that a two-cluster is the optimal structure. This solution distinguishes between controlled and autonomous motivations, but not between external and introjected motivations. This validates the structure of the negative and positive aspects of autonomy. On the other hand, Duda-Hart stopping rule suggests a three-group solution, distinguishing between the three types of motivations. Thus, the structure of the autonomy measure is validated insofar as the three kinds of motivations, and their positive and negative structure, but the apparent relative position of controlled and introjected motivations differs for some domains.

Women

In the case of women, both Calinski-Harabasz and Duda-Hart stopping rules suggest that a three-group structure is the most distinct hierarchical structure, validating the distinction between controlled, introjected, and autonomous motivations. The three clusters distinguish the three types of questions. When we consider the full set of domains, the two closer clusters are the ones related to external and identified motivation – that is, introjected motivations changed with autonomous motivations. But when we consider the smaller set of questions and the larger sample, we find that the three motivations appear as three clustered, and are presented in the expected ordering.

Overall, the structure that emerges from this analysis corroborates the separation between controlled and autonomous motivations. In the small sample with all domains, the introjected motivations do not always appear in the expected ranking. But in the large sample with a subset of domains, the expected structure is independently ratified.

4.1.2 Correlations within Areas of Decision-making

Table A.2 presents the Spearman and Pearson correlation matrices for each domain, considering the samples of men and women separately.²⁵

Table A.2: Matrix of correlations between motivation subscales

	Sample of men							
	Spearman		Pearson (svy)		Spearman		Pearson (svy)	
	External	Introj.	External	Introj.	External	Introj.	External	Introj.
Agricultural production								
Introjected	0.432***		0.419***		0.199***		0.134**	
Autonomous	0.020	0.002	0.108***	0.062**	0.226***	0.038*	0.264***	0.058*
What inputs								
Introjected	0.402***		0.393***		0.216***		0.152**	
Autonomous	-0.001	-0.020	0.066**	0.049*	0.253***	0.041**	0.288***	0.060*
What crops to grow								
Introjected	0.435***		0.435***		0.232***		0.159***	
Autonomous	-0.014	-0.067***	0.064**	-0.017	0.241***	0.054***	0.290***	0.073**
Take crops to market								
Introjected	0.431***		0.417***		0.241***		0.174***	
Autonomous	-0.071***	-0.046**	0.012	0.017	0.224***	0.041**	0.274***	0.082***
Livestock raising								
Introjected	0.462***		0.458***		0.315***		0.235***	
Autonomous	-0.015	-0.073**	0.046	-0.022	0.193***	0.051***	0.225***	0.089***
Nonfarm business								
Introjected	0.476***		0.479***		0.175***		0.157**	
Autonomous	-0.097***	-0.062**	-0.002	0.009	0.330***	0.065***	0.351***	0.072*
Wage and employment								
Introjected	0.492***		0.487***		0.238***		0.141**	
Autonomous	-0.026	-0.036*	0.047	0.028	0.244***	0.015	0.290***	0.032
Minor hh expenditures								
Introjected	0.490***		0.485***		0.359***		0.309***	
Autonomous	-0.111***	-0.019	-0.052**	0.019	0.166***	0.065***	0.214***	0.113***
Health								
Introjected	0.470***		0.426***		0.381***		0.307***	
Autonomous	0.051***	-0.021	0.123***	0.040	0.211***	0.059***	0.251***	0.113***
Protect from violence								
Introjected	0.450***		0.477***		0.239***		0.200**	
Autonomous	0.075***	0.041*	0.144***	0.124***	0.182***	-0.061**	0.227***	-0.030
Express religious faith								
Introjected	0.520***		0.504***		0.423***		0.434***	
Autonomous	0.129***	0.039**	0.214***	0.121***	0.185***	0.047***	0.216***	0.097***
Def. of daily tasks								
Introjected	0.502***		0.473***		0.422***		0.350***	

²⁵ Spearman correlation coefficients do not take into account the survey design. The Pearson correlation coefficients displayed were computed pairwise and they take into account the survey design.

Autonomous	-0.054***	-0.022	0.038*	0.038*	0.173***	0.085***	0.194***	0.138***
Family planning	External	Introj.	External	Introj.	External	Introj.	External	Introj.
Introjected	0.555***		0.571***		0.392***		0.346***	
Autonomous	-0.040**	-0.053***	0.039	0.015	0.161***	0.0158	0.200***	0.074**

Note: * significant at 10%; ** significant at 5%; *** significant at 1%.

4.2 Reliability

We performed an additional test of reliability using nonparametric Item Response Theory (IRT), the Mokken Scale Procedure (MSP). This is ‘an automated item selection procedure for selecting unidimensional scales of polytomous items from multidimensional datasets’ (Hemker, Sijtsma and Molenaar, 1995, p. 337).

The MSP is based on Loevinger’s H coefficient. This coefficient corresponds to the observed between-item covariance divided by the maximum possible covariance given the marginal distribution of the two items. The coefficient can be computed for a pair of items i and j (H_{ij}); for item i (H_i), by averaging H_{ij} across j ; and for a whole scale (H), averaging H_i across i . Coefficient H_i may be interpreted as a measure of the discrimination power of item i and, hence, the coefficient H can be seen as a measure of the discrimination of the scale (Sijtsma, Maijer, and Van der Ark, 2011). Mokken (1971) suggested the following rule to describe the quality of a scale:

Loevinger’s H	Scale quality
$0 \leq H < 0.3$	Unscalable
$0.3 \leq H < 0.4$	Weak
$0.4 \leq H < 0.5$	Medium
$0.5 \leq H$	Strong

This procedure allows us to test if the questions that are supposed to measure different types of motivation are grouped into different Mokken scales. We assumed a lower bound for Loevinger’s H of 0.5. We performed this test considering the full set of domains and restricting the analysis to the domains related to agriculture, analyzing men and women separately.

Men

Considering the full set of items, the MSP identified two scales. The first scale grouped the autonomous motivation questions, and it had an H coefficient of 0.87. The second scale combined all external and introjected motivation questions, and it had an H coefficient of 0.59, so in both cases the scale quality was strong, but the external and introjected questions were grouped together. This dimension structure is very similar to the one reflected by the cluster analysis – but remember it is only for 365 men.

Considering the set of items related to agriculture and the larger sample, the results were much more in line with our measurement model. The MSP identified three scales, each grouping the set of items intended to measure one of the types of motivations. The respective H coefficients varied between 0.67 for introjected motivation and 0.90 for identified motivation, all indicating strong scale quality.

Women

Considering the full set of items and smaller sample, the MSP identified five scales. The first combined all external and identified motivation questions, and had an H coefficient of 0.75. The introjected motivation questions were separated into four different scales. The first of these scales grouped the questions related to agriculture. The second scale grouped the questions regarding expression of religious faith, definition of daily tasks, and family planning. The third scale grouped the domains of household minor expenditures and health. Finally, the fourth scale grouped the questions regarding non-farming business and own wage and salary employment. The introjected questions regarding raising livestock and protection from violence were not included in any scale. The MSP grouping of indicators is intuitively consistent with different spheres of decision-making in a woman's life. Similar to the case of men, when we only considered the questions related to agriculture and the larger sample, the MSP identified three scales, each grouping the set of items intended to measure one of the types of motivations. The respective H coefficients varied between 0.71 for introjected motivation and 0.91 for external motivation. Thus, for both men and women the Mokken Scale Procedure ranks the scale qualities in their highest category and this procedure, together with the excellent strength of Cronbach's alpha, validates the reliability of the relative autonomy index for both women and men.

5. External Validity

We started by comparing the average autonomy indices across different population subgroups. We defined the groups, splitting the sample in terms of gender, age group, level of education, per capita expenditure quintile, and geographic locations (administrative division). The purpose of this exercise was to investigate if there are population subgroups that are clearly more autonomous than others.

Table A.3 presents the average indicators by gender and the results of the test of equal means across gender. At a significance level of 10%, we reject the null hypothesis in seven of the 13 domains. Men are on average more autonomous in decisions related to economic activities ('what crops to grow', 'when and who to take crops to market', 'non-farming business and own wage and salaried employment'). Women, on the other hand, tend to report higher levels of autonomy in the domains of 'protection from violence', 'expression of religious faith', and 'family planning'. In terms of values of empowerment, the male RAI

ranges from 3.23 to 4.43 and the women's RAI varies from 3.39 to 4.55. The domain of 'defining daily tasks' has the highest RAI value for both men and women, and is not significantly different. One also observes gender parity for domains such as decisions regarding minor household expenditures; what to do in health emergencies; and decisions regarding livestock, inputs for agriculture, and agricultural production.

Table A.3: Average RAI by gender

Domains	Male sample		Female sample		Means comparison	
	Mean	Obs	Mean	Obs	Difference	p-value
Agricultural production	4.24	2,886	4.10	2,637	0.14	0.36
Inputs for agriculture	4.25	2,852	4.01	2,599	0.24	0.13
Types of crops to grow	4.29	2,853	4.01	2,620	0.28	0.08
Take crops to market	4.28	2,664	3.94	2,489	0.34	0.03
Livestock raising	4.21	2,813	4.05	3,232	0.16	0.31
Nonfarm business	4.20	2,224	3.39	1,607	0.80	0.00
Wage and salary employment	4.22	2,641	3.71	1,974	0.51	0.00
Minor household expenditures	4.30	4,506	4.24	5,169	0.06	0.63
Health	3.95	3,989	4.04	4,802	-0.10	0.42
Protection from violence	3.23	1,663	4.07	1,526	-0.84	0.00
Express religious faith	3.62	3,850	4.29	3,840	-0.67	0.00
Define daily tasks	4.43	4,268	4.55	5,064	-0.12	0.41
Family planning	3.69	3,401	4.14	4,098	-0.45	0.00

Note: P-values computed using svy command, assuming equal variance across groups.

Across domains, men experience the highest autonomy, after defining daily tasks, in activities like minor household expenditures, types of crops to grow, taking crops to market, agricultural inputs, and agricultural production, followed by wage and salary employment. Women's highest RAI after defining daily tasks concerns their expression of religious faith, followed by minor household expenditures, family planning, and agricultural production.

The means displayed in Table A.4 suggest that in most domains the average autonomy of women increases with age, while in the sample of men the pattern of autonomy usually has a mild u-shape, but reaches the highest value for men in the oldest category in all domains.

Table A.5 presents the average RAIs by education level. In the sample of men, autonomy tends to increase with education. Men with a secondary school education have higher autonomy than the unschooled in every domain except family planning, where autonomy values are equal. The autonomy of men with a primary school education is between the autonomy of the other two groups of men in most domains, except non-farm business, health, religion, defining daily tasks, and family planning. In the sample of women, autonomy in every domain is slightly higher for women who have completed secondary school than for women who have no education. Women with a primary school education have autonomy levels

women, autonomy in every domain is slightly higher for women who have completed secondary school than for women who have no education. Women with a primary school education have autonomy levels equal to or between the other education categories in all except three domains: inputs for agriculture, wages and salaries, and protection from violence.

Table A.4: Average RAI by gender and age group

Domains	Sample of men						Sample of women					
	Age < 26		26 ≤ Age ≤ 55		Age > 55		Age < 26		26 ≤ Age ≤ 55		Age > 55	
	Mean	Obs	Mean	Obs	Mean	Obs	Mean	Obs	Mean	Obs	Mean	Obs
Agricultural production	4.17	193	4.15	2,016	4.57	677	4.05	430	4.07	2,020	4.55	187
Inputs for agriculture	4.21	191	4.13	1,998	4.64	663	3.92	436	3.98	1,982	4.54	181
Types of crops to grow	4.21	192	4.16	2,001	4.73	660	3.91	447	3.99	1,992	4.59	181
Take crops to market	4.26	176	4.16	1,868	4.67	620	4.01	432	3.88	1,880	4.38	177
Livestock raising	4.25	189	4.06	1,995	4.68	629	3.88	588	4.06	2,425	4.46	219
Nonfarm business	3.88	150	4.23	1,686	4.15	388	3.08	348	3.49	1,173	3.18	86
Wage and salary employment	4.50	248	4.11	1,962	4.59	431	3.45	424	3.76	1,417	4.02	133
Minor household expenditures	4.35	384	4.23	3,143	4.53	979	3.94	1054	4.30	3,698	4.40	417
Health	4.12	344	3.85	2,782	4.23	863	3.82	976	4.09	3,455	4.14	371
Protection from violence	3.10	131	3.11	1,189	3.75	343	4.02	297	4.10	1,123	3.83	106
Express religious faith	3.53	307	3.49	2,665	4.06	878	4.20	775	4.28	2,769	4.65	296
Define daily tasks	4.25	365	4.37	2,979	4.67	924	4.36	1060	4.57	3,604	4.82	400
Family planning	4.04	205	3.65	2,623	3.80	573	4.12	954	4.15	2,993	3.91	151

Table A.5: Average RAI by education level

Domains	Sample of men						Sample of women					
	No edu		Primary		Secondary		No edu		Primary		Secondary	
	Mean	Obs	Mean	Obs	Mean	Obs	Mean	Obs	Mean	Obs	Mean	Obs
Agricultural production	4.19	1,400	4.21	693	4.35	665	3.95	1,264	4.21	710	4.25	633
Inputs for agriculture	4.11	1,392	4.33	684	4.47	653	3.85	1,259	4.15	696	4.12	613
Types of crops to grow	4.20	1,394	4.33	683	4.47	652	3.82	1,265	4.15	705	4.20	619
Take crops to market	4.18	1,290	4.35	615	4.41	634	3.77	1,207	4.09	664	4.09	589
Livestock raising	4.12	1,428	4.27	668	4.34	613	4.03	1,626	4.03	857	4.14	718
Nonfarm business	4.13	1,061	4.02	553	4.47	519	3.25	804	3.38	416	3.69	371
Wage and salary employment	4.05	1,442	4.17	624	4.60	480	3.60	1,056	3.84	504	3.78	381
Minor household expenditures	4.16	2,237	4.38	1,077	4.49	995	4.19	2,498	4.26	1,371	4.27	1,233
Health	3.92	1,970	3.88	937	4.06	904	3.98	2,327	4.06	1,268	4.09	1,145
Protection from violence	3.00	776	3.20	391	3.55	405	3.76	751	4.47	379	4.22	378
Express religious faith	3.60	1,882	3.50	926	3.67	873	4.11	1,925	4.40	963	4.46	901
Define daily tasks	4.38	2,100	4.50	1,020	4.48	957	4.48	2,433	4.58	1,344	4.61	1,219
Family planning	3.70	1,704	3.63	809	3.70	748	3.98	1,755	4.18	1,174	4.34	1,106

Table A.6 presents the average RAIs by per capita expenditure quintile. The autonomy of both men and women in all domains increases with the level of expenditure of the household indicating a positive correlation between autonomy and expenditure. Comparing also across gender, men in the highest quintile have the highest level of autonomy (higher than women in the highest quintile) in all domains except family planning, definition of daily tasks, and the expression of religious faith. Men in the lowest quintile, interestingly, have the lowest autonomy

(lower than women in the lowest quintile) in every single domain except nonfarm business.

Table A.7 presents the average RAIs by geographical division. Men in Khulna have the highest RAI in all domains except religion, and men living in Rangpur have the lowest RAI in all domains except minor household expenditures, religion, and family planning. Rajshahi has the second lowest achievements in all levels (and the lowest in the three domains mentioned above). Furthermore, the range in male autonomy is remarkably high, with male autonomy rates above 6 for nine domains

in Khulna, and below 2.2 in 10 domains of Rangpur. Therefore, male autonomy is strongly regional.

Among women, the range of RAI across divisions is lower. Khulna still has the highest autonomy in eight domains and Rangpur the lowest in

seven, with Rajshahi also showing low autonomy. However interestingly, in Barisal, women have the highest autonomy of all divisions in three domains, and the lowest in two others, showing quite a polarized setting.

Table A.6: Average RAI by per capita expenditure quintile

Indicators	Sample of men						Sample of women					
	Lowest		Middle		Highest		Lowest		Middle		Highest	
	Mean	Obs	Mean	Obs	Mean	Obs	Mean	Obs	Mean	Obs	Mean	Obs
Agricultural production	3.25	449	4.48	603	5.04	593	3.83	435	4.12	548	4.42	577
Inputs for agriculture	3.39	443	4.46	596	5.04	583	3.54	431	4.19	538	4.34	564
Types of crops to grow	3.41	444	4.50	596	5.07	583	3.62	441	4.10	539	4.33	567
Take crops to market	3.22	403	4.57	548	4.97	555	3.48	421	4.05	504	4.44	557
Livestock raising	3.23	501	4.46	589	4.99	537	3.80	631	4.06	647	4.58	613
Nonfarm business	3.30	389	4.41	453	4.98	468	2.75	303	3.51	320	4.08	321
Wage and salary employment	3.53	637	4.53	576	5.43	346	3.67	466	3.53	408	4.35	338
Minor household expenditures	3.62	843	4.51	928	4.91	888	4.09	984	4.34	1,044	4.53	1,094
Health	3.22	747	4.17	843	4.54	772	3.81	912	4.15	954	4.30	1,018
Protection from violence	1.92	289	3.29	338	4.57	349	3.98	274	4.18	307	4.42	341
Express religious faith	3.04	690	3.94	792	3.99	768	4.05	753	4.37	745	4.95	800
Define daily tasks	3.74	788	4.68	876	5.00	856	4.21	964	4.65	1,006	5.06	1,076
Family planning	3.25	672	3.96	731	4.20	604	3.89	813	4.17	855	4.62	787

Table A.7: Average RAI by region

	Sample of men							Sample of women						
	Barisal	Chittagong	Dhaka	Khulna	Rajshahi	Rangpur	Sylhet	Barisal	Chittagong	Dhaka	Khulna	Rajshahi	Rangpur	Sylhet
Agricultural production	3.79	4.92	4.99	6.13	3.08	1.88	5.14	4.94	3.57	4.58	5.49	3.68	3.02	3.65
Inputs for agriculture	3.30	4.84	5.03	6.33	2.92	2.08	5.17	4.83	3.50	4.73	5.35	3.44	2.84	3.61
Types of crops to grow	3.47	5.06	5.07	6.34	2.93	1.90	5.46	4.67	3.31	4.84	5.55	3.48	2.85	3.29
Take crops to market	3.49	4.85	5.18	6.39	2.70	2.12	5.61	4.49	3.46	5.01	5.56	3.13	2.59	3.35
Livestock raising	3.73	5.12	4.91	6.23	2.94	2.24	5.12	2.06	3.67	5.30	5.48	3.11	2.88	3.92
Nonfarm business	3.46	5.27	5.25	6.57	2.55	1.90	5.08	4.57	2.87	4.15	5.70	2.89	2.11	2.57
Wage and employment	3.99	5.72	5.04	6.60	2.46	1.96	4.54	5.86	3.40	4.67	5.30	2.25	2.35	3.58
Minor hh expenditures	3.64	5.07	4.92	6.29	2.33	2.63	5.07	3.51	3.81	5.30	5.35	3.13	3.21	4.00
Health	3.68	4.49	4.84	5.58	2.59	2.18	3.22	3.29	3.47	5.10	5.25	3.00	2.90	4.31
Protection from violence	3.22	4.36	4.59	4.95	0.98	0.89	2.34	5.96	2.93	5.22	5.33	3.92	1.96	5.53
Express religious faith	3.41	5.07	4.83	4.53	0.81	2.07	2.91	6.21	4.56	4.79	5.63	3.15	3.21	4.45
Define daily tasks	3.54	5.22	5.02	6.12	2.99	2.56	4.35	2.57	4.35	5.65	5.84	3.43	3.31	4.49
Family planning	3.21	4.96	4.75	5.05	1.60	1.95	3.82	2.69	4.03	5.42	5.22	2.61	3.10	4.40

Note: Values in bold correspond to the highest regional average.

5.1 Correlations

Tables A.8 and A.9 present the Spearman and Kendall tau rank correlation coefficients between the domain-specific relative autonomy indicators and a set of common proxies of empowerment.

Table A.8: Spearman correlations between RAI and other indicators

RAI	General functioning		Empowerment			Agency		Domain-specific functionings	
	Education	Income	Make important decisions	Mobility	Contact friends & relatives	Make changes in community	Influence in community	Feel make decisions	Satisfaction with decisions
	(1)	(2)	(3)	(4)	(5)	(6)	(7)	(8)	(9)
Panel A: Sample of men									
Agricultural production	0.01	0.14***	0.18***	0.23***	0.31***	-0.03*	0.05**	0.08***	0.38***
Purchase inputs	0.02	0.13***	0.18***	0.24***	0.33***	-0.04**	0.05***	0.06***	0.40***
Decide on crops	0.02	0.12***	0.17***	0.23***	0.30***	-0.04*	0.04**	0.07***	0.41***
Take crops to markets	0.01	0.12***	0.19***	0.24***	0.31***	-0.01	0.06***	0.07***	0.42***
Livestock raising	0.02	0.15***	0.18***	0.22***	0.30***	0.00	0.07***	0.10***	0.39***
Non-farm activity	0.01	0.14***	0.21***	0.25***	0.31***	0.01	0.09***	0.05**	0.42***
Wage and employment	0.06***	0.15***	0.21***	0.23***	0.31***	-0.04**	0.03	0.09***	0.48***
Minor hh expenditures	0.03**	0.12***	0.17***	0.21***	0.27***	-0.02	0.02	0.04**	0.36***
Health	0.01	0.11***	0.18***	0.24***	0.25***	0.04**	0.08***	0.06***	0.39***
Protection from violence	0.04*	0.22***	0.15***	0.16***	0.25***	0.17***	0.12***	-0.02	0.38***
Religious faith	0.01	0.09***	0.10***	0.14***	0.15***	-0.10***	0.00	0.03	0.24***
Daily tasks	0.00	0.10***	0.12***	0.20***	0.27***	-0.05***	0.01	0.07***	0.37***
Family planning	0.00	0.07***	0.14***	0.22***	0.21***	-0.02	0.01	0.09***	0.27***
Panel B: Sample of women									
Agricultural production	0.04**	0.07***	0.17***	0.11***	0.08***	0.10***	0.06***	0.04**	0.31***
Purchase inputs	0.04*	0.09**	0.20***	0.13***	0.10***	0.08***	0.08***	0.06***	0.32***
Decide on crops	0.04**	0.08***	0.18***	0.12***	0.09***	0.08***	0.08***	0.06***	0.33***
Take crops to markets	0.03*	0.09***	0.19***	0.11***	0.11***	0.11***	0.08***	0.09***	0.32***
Livestock raising	-0.01	0.06***	0.12***	0.05***	0.05***	0.09***	0.08***	0.09***	0.36***
Non-farm activity	0.05*	0.12***	0.15***	0.10***	0.07***	0.12***	0.07***	0.06**	0.32***
Wage and employment	0.02	0.03	0.10***	0.06***	0.05**	0.03	0.01	0.07***	0.31***
Minor hh expenditures	0.01	0.05***	0.13***	0.06***	0.04***	0.08***	0.08***	0.07***	0.35***
Health	0.00	0.04***	0.14***	0.08***	0.07***	0.06***	0.09***	0.03**	0.33***
Protection from violence	0.06**	0.04*	0.08***	0.06**	0.14***	-0.01	-0.04	0.15***	0.35***
Religious faith	0.05***	0.09***	0.08***	0.04**	-0.02	0.10***	0.05***	0.05***	0.33***
Daily tasks	0.01	0.07***	0.08***	0.03**	0.04***	0.08***	0.05***	0.10***	0.32***
Family planning	0.02	0.05***	0.12***	0.04***	0.02	0.09***	0.11***	0.01	0.36***

Note: * significant at 10%; ** significant at 5%; *** significant at 1%.

Table A.9: Kendall Tau correlations between RAI and other indicators

RAI	General functioning		Empowerment			Agency		Domain-specific functionings	
	Education	Income	Make important decisions	Mobility	Contact friends & relatives	Make changes in community	Influence in community	Feel make decisions	Satisfaction with decisions
	(1)	(2)	(3)	(4)	(5)	(6)	(7)	(8)	(9)
Panel A: Sample of men									
Agricultural production	0.01	0.09***	0.12***	0.15***	0.20***	-0.02	0.03**	0.03***	0.24***
Purchase inputs	0.01	0.08***	0.12***	0.16***	0.21***	-0.02**	0.03***	0.02***	0.25***
Decide on crops	0.01	0.08***	0.11***	0.14***	0.20***	-0.02*	0.03**	0.02***	0.26***
Take crops to markets	0.01	0.08***	0.12***	0.15***	0.20***	-0.01	0.04***	0.02***	0.26***
Livestock raising	0.01	0.10***	0.12***	0.14***	0.20***	0.00	0.05***	0.05***	0.25***
Non-farm activity	0.01	0.09***	0.14***	0.16***	0.20***	0.00	0.06***	0.02**	0.26***
Wage and employment	0.03***	0.10***	0.14***	0.15***	0.20***	-0.02**	0.02	0.03***	0.30***
Minor hh expenditures	0.02**	0.07***	0.11***	0.14***	0.18***	-0.01	0.01	0.02**	0.23***
Health	0.00	0.07***	0.12***	0.15***	0.16***	0.02**	0.05***	0.03***	0.25***
Protection from violence	0.03*	0.14***	0.10***	0.10***	0.16***	0.11***	0.08***	-0.01	0.24***
Religious faith	0.01	0.06***	0.06***	0.09***	0.10***	-0.06***	0.00	0.01	0.15***
Daily tasks	0.00	0.07***	0.08***	0.13***	0.18***	-0.03***	0.01	0.02***	0.23***
Family planning	0.00	0.05***	0.09***	0.14***	0.14***	-0.01	0.01	0.05***	0.17***
Panel B: Sample of women									
Agricultural production	0.02**	0.05***	0.11***	0.07***	0.05***	0.05***	0.04***	0.02**	0.18***
Purchase inputs	0.02*	0.06***	0.13***	0.08***	0.07***	0.05***	0.05***	0.04***	0.19***
Decide on crops	0.03**	0.05***	0.11***	0.07***	0.06***	0.04***	0.05***	0.03***	0.20***
Take crops to markets	0.02*	0.06***	0.12***	0.07***	0.07***	0.06***	0.05***	0.05***	0.19***
Livestock raising	-0.01	0.04***	0.07***	0.03***	0.03***	0.05***	0.05***	0.04***	0.21***
Non-farm activity	0.03*	0.08***	0.10***	0.07***	0.05***	0.07***	0.04***	0.03**	0.20***
Wage and employment	0.01	0.02	0.06***	0.04***	0.03**	0.01	0.01	0.04***	0.19***
Minor hh expenditures	0.00	0.03***	0.09***	0.04***	0.03***	0.04***	0.05***	0.04***	0.21***
Health	0.00	0.03***	0.09***	0.05***	0.04***	0.03***	0.06***	0.02**	0.19***
Protection from violence	0.04**	0.03*	0.05***	0.04**	0.09***	-0.01	-0.03	0.08***	0.21***
Religious faith	0.03***	0.06***	0.05***	0.02**	-0.02	0.05***	0.03***	0.02***	0.18***
Daily tasks	0.00	0.04***	0.05***	0.02**	0.03***	0.04***	0.03***	0.03***	0.17***
Family planning	0.01	0.03***	0.08***	0.03***	0.01	0.05***	0.07***	0.00	0.19***

Note: * significant at 10%; ** significant at 5%; *** significant at 1%.

5.2 Regression Analysis

5.2.1 Empirical Specification

We list below the covariates included in Equations (1) and (2)

The vector \mathbf{X}_i includes:

- the individual's age,
- dummy variables that assume the value of one
 - o if the individual is the head of the household;
 - o if the respondent is married;
 - o if the household head's occupation is related to agriculture (farming, fishing or fish raising, and livestock and poultry raising)
- the number of household members; and
- the number of household members younger than six years old.

The vector \mathbf{F}_i includes:

- individual's education measured as years of schooling;²⁶
- a dummy that equals one if the individual's occupation is related to agriculture; and
- an indicator of health that equals one if respondent can easily 'stand up after sitting down', 'walk for 5 km' and 'carry 20 liters of water for 20 meters'.

The vector \mathbf{H}_i includes:

- housing quality indicators, namely
 - o an indicator of sanitation,²⁷
 - o drinking water,²⁸ and
 - o cooking fuel.²⁹
- three asset dummies,
 - o one proxying for access to information (equal to one if household has a TV, radio, phone, or mobile phone),
 - o another for support of mobility (equal to one if household owns a bicycle, rickshaw, van, boat, or motorbike), and
 - o another for support of livelihood (equal to one if household owns livestock or cultivable land); and
- per capita expenditure quintile to which the household belongs.³⁰

26 Measuring education level with dummies for level of education achieved instead of years of schooling does not affect the conclusions presented below.

27 Dummy equals one if household members use pucca, or sanitary toilet with or without flush.

28 Dummy equals one if source of drinking water is piped water, own tube well, rain water, or deep tube well for irrigation.

29 Dummy equals one if main source of cooking fuel is electricity, supply gas, LPG, or kerosene.

30 The housing characteristics and assets dummies capture whether the household has basic conditions and assets. The per capita expenditure quintile proxies the relative position of the household in terms of income. The highest correlations of per capita expenditure quintile are with sanitation (0.28), cooking fuel (0.11), assets for access to information (0.26) and assets for support to livelihood (0.10). None of these correlations is likely to lead to multicollinearity problems.

The summary statistics of all the variables used are presented in Table A.10.

Table A.10: Summary statistics

Variables	Sample of men					Sample of women				
	Obs.	Mean	Std. Dev.	Min	Max	Obs.	Mean	Std. Dev.	Min	Max
Dependent variables										
RAI in domains:										
Agricultural production	2,886	4.24	3.52	-7	9	2,637	4.10	3.25	-9	9
What inputs for agriculture	2,852	4.25	3.55	-8	9	2,599	4.01	3.29	-9	9
What types of crops to grow	2,853	4.29	3.63	-6	9	2,620	4.01	3.24	-9	9
Who/when to take crops to market	2,664	4.28	3.68	-6	9	2,489	3.94	3.36	-9	9
Livestock raising	2,813	4.21	3.62	-9	9	3,232	4.05	3.49	-9	9
Nonfarming business activities	2,224	4.20	3.71	-8	9	1,607	3.39	3.33	-9	9
Wage and salary employment	2,641	4.22	3.61	-8	9	1,974	3.71	3.29	-9	9
Minor household expenditures	4,506	4.30	3.67	-8	9	5,169	4.24	3.40	-9	9
Deal with serious health problems	3,989	3.95	3.55	-9	9	4,802	4.04	3.35	-9	9
Protection from violence	1,663	3.23	3.52	-9	9	1,526	4.07	3.19	-9	9
Expression of religious faith	3,850	3.62	3.72	-9	9	3,840	4.29	3.48	-9	9
Definition of daily tasks	4,268	4.43	3.60	-8	9	5,064	4.55	3.42	-9	9
Family planning	3,401	3.69	3.83	-9	9	4,098	4.14	3.53	-9	9
General indicators of empowerment										
Power to make important decisions	4,571	6.41	2.12	1	10	5,498	6.14	2.19	1	10
Possibilities to go to other places	4,571	6.01	2.19	1	10	5,498	6.13	2.13	1	10
Contact with friends and relatives	4,571	6.21	2.18	1	10	5,498	6.60	2.26	1	10
Domain-specific indicators about decision-making										
Feel can make decisions in domains:										
Agricultural production	4,571	0.76	0.43	0	1	5,498	0.29	0.46	0	1
What inputs for agriculture	4,571	0.76	0.43	0	1	5,498	0.30	0.46	0	1
What types of crops to grow	4,571	0.76	0.43	0	1	5,498	0.31	0.46	0	1
Who/when to take crops to market	4,571	0.75	0.44	0	1	5,498	0.31	0.46	0	1
Livestock raising	4,571	0.68	0.47	0	1	5,498	0.54	0.50	0	1
Nonfarming business activities	4,571	0.68	0.47	0	1	5,498	0.23	0.42	0	1
Wage and salary employment	4,571	0.73	0.45	0	1	5,497	0.30	0.46	0	1
Minor household expenditures	4,571	0.84	0.37	0	1	5,496	0.60	0.49	0	1
Deal with serious health problems	4,571	0.71	0.45	0	1	5,497	0.50	0.50	0	1
Protection from violence	4,571	0.45	0.50	0	1	5,497	0.18	0.38	0	1
Expression of religious faith	4,571	0.86	0.34	0	1	5,496	0.65	0.48	0	1
Definition of daily tasks	4,571	0.91	0.28	0	1	5,496	0.84	0.36	0	1
Family planning	4,571	0.53	0.50	0	1	5,493	0.65	0.48	0	1
Satisfaction with decisions made in domains:										
Agricultural production	2,964	4.14	0.99	1	5	2,768	4.30	0.90	1	5
What inputs for agriculture	2,928	4.10	0.99	1	5	2,715	4.26	0.89	1	5
What types of crops to grow	2,932	4.13	0.96	1	5	2,725	4.26	0.90	1	5
Who/when to take crops to market	2,743	4.09	0.98	1	5	2,584	4.22	0.90	1	5
Livestock raising	2,879	4.14	0.93	1	5	3,213	4.42	0.76	1	5
Nonfarming business activities	2,308	4.11	0.97	1	5	1,607	4.24	0.85	1	5
Wage and salary employment	2,705	4.12	0.89	1	5	2,044	4.17	0.88	1	5
Minor household expenditures	4,521	4.17	0.90	1	5	5,201	4.46	0.74	1	5
Deal with serious health problems	4,029	4.05	0.95	1	5	4,846	4.37	0.79	1	5
Protection from violence	1,756	3.97	0.90	1	5	1,589	4.17	0.92	1	5
Expression of religious faith	3,879	4.28	0.87	1	5	3,804	4.55	0.70	1	5
Definition of daily tasks	4,289	4.29	0.82	1	5	5,059	4.57	0.69	1	5
Family planning	3,438	4.27	0.81	1	5	4,106	4.60	0.71	1	5

Table A.10: Summary statistics (cont.)

Variables	Sample of men					Sample of women				
	Obs.	Mean	Std. Dev.	Min	Max	Obs.	Mean	Std. Dev.	Min	Max
Individual and household characteristics										
Age (in years)	4,571	44.43	13.82	14	95	5,498	36.71	11.57	6	99
Household head (=1, 0 otherwise)	4,571	0.96	0.20	0	1	5,498	0.13	0.33	0	1
Marital status (=1 if married, 0 otherwise)	4,571	0.95	0.21	0	1	5,498	0.95	0.23	0	1
Household size	4,566	4.87	1.78	2	17	5,498	4.73	1.78	1	17
No. of household members < 6 years old	4,571	0.66	0.74	0	6	5,498	0.66	0.75	0	6
Household head occupation is related to agriculture (farming, fishing, or livestock/poultry raising)	4,571	0.45	0.50	0	1	5,498	0.43	0.50	0	1
Years of education	4,571	3.39	4.05	0	16	5,497	3.22	3.57	0	16
Health (=1 if can easily 'stand up after sitting down', 'walk for 5 km' and 'carry 20 litres of water for 20 meters', 0 otherwise)	4,567	3.95	1.85	3	12	5,495	4.26	1.92	3	12
Occupation related to agriculture (=1 if farming, fishing, or livestock/poultry raising, 0 otherwise)	4,570	0.44	0.50	0	1	5,498	0.50	0.50	0	1
Occupation housewife (=1, 0 otherwise)	4,570	0.00	0.00	0	0	5,498	0.42	0.49	0	1
Household members use pucca, or sanitary with or without flush (=1, 0 otherwise)	4,566	0.26	0.44	0	1	5,498	0.27	0.44	0	1
Source of drinking water is piped water, own tube well, rain water, or deep tube well for irrigation (=1, 0 otherwise)	4,571	0.88	0.33	0	1	5,498	0.87	0.33	0	1
Main source of cooking fuel is electricity, supply gas, LPG, or kerosene (=1, 0 otherwise)	4,571	0.03	0.17	0	1	5,498	0.03	0.17	0	1
Household owns a TV, a radio, a phone, or a mobile phone (=1, 0 otherwise)	4,571	0.79	0.41	0	1	5,498	0.78	0.41	0	1
Household owns a bicycle, a rickshaw, a van, a boat, or a motorbike (=1, 0 otherwise)	4,571	0.42	0.49	0	1	5,498	0.39	0.49	0	1
Household owns livestock or cultivable land (=1, 0 otherwise)	4,571	0.66	0.48	0	1	5,498	0.63	0.48	0	1
Per capita expenditure quintile	4,566	2.89	1.40	1	5	5,498	2.91	1.41	1	5
Division dummy 1 (Barisal)	4,566	0.06	0.24	0	1	5,498	0.06	0.24	0	1
Division dummy 2 (Chittagong)	4,566	0.15	0.36	0	1	5,498	0.18	0.39	0	1
Division dummy 3 (Dhaka)	4,566	0.29	0.45	0	1	5,498	0.28	0.45	0	1
Division dummy 4 (Khulna)	4,566	0.12	0.33	0	1	5,498	0.12	0.32	0	1
Division dummy 5 (Rajshahi)	4,566	0.17	0.37	0	1	5,498	0.15	0.36	0	1
Division dummy 6 (Rangpur)	4,566	0.14	0.34	0	1	5,498	0.13	0.34	0	1
Division dummy 7 (Sylhet)	4,566	0.07	0.26	0	1	5,498	0.07	0.26	0	1

5.2.2 Results

Table A.11 displays the estimates of Equation (1) using an ordered probit.

Table A.11. Estimates of Equation (1) using an ordered probit model

Variables	Domains							
	Agriculture production		Livestock raising		Non-farming business activity		Protection from violence	
	Men	(2)	Men	Women	Men	Women	Men	Women
Age	0.003 (0.002)	0.002 (0.003)	0.002 (0.002)	0.000 (0.002)	-0.000 (0.002)	-0.001 (0.003)	0.000 (0.002)	0.005 (0.004)
Household head	0.098 (0.188)	0.012 (0.087)	-0.062 (0.155)	0.023 (0.078)	0.250 (0.171)	0.142 (0.126)	0.143 (0.191)	0.262*** (0.083)
No. of household members	0.032* (0.017)	0.009 (0.018)	0.020 (0.019)	-0.025 (0.018)	0.056*** (0.017)	0.015 (0.025)	0.033 (0.020)	-0.004 (0.023)
No. of members <6	0.067* (0.036)	0.070* (0.041)	0.082** (0.038)	0.034 (0.038)	-0.031 (0.040)	-0.131*** (0.041)	0.003 (0.048)	0.086 (0.055)
Years of education	-0.007 (0.006)	0.008 (0.008)	-0.012* (0.007)	-0.004 (0.007)	-0.013* (0.007)	0.004 (0.010)	-0.001 (0.007)	0.026** (0.011)
Occupation in agriculture	0.120 (0.207)	-0.229*** (0.062)	-0.025 (0.222)	-0.158*** (0.053)	0.246 (0.214)	-0.103 (0.070)	-0.066 (0.270)	-0.196** (0.080)
Sanitation	-0.169*** (0.062)	0.116* (0.061)	-0.073 (0.072)	0.150** (0.061)	-0.064 (0.075)	0.103 (0.078)	-0.364*** (0.096)	0.175** (0.088)
Cooking fuel	-0.300** (0.140)	-0.212 (0.135)	-0.024 (0.152)	-0.115 (0.122)	-0.375** (0.171)	-0.062 (0.193)	-0.159 (0.181)	-0.306 (0.191)
Assets - Access to information	0.134** (0.061)	0.072 (0.067)	0.028 (0.062)	0.037 (0.058)	0.090 (0.062)	0.156** (0.079)	-0.000 (0.066)	0.058 (0.084)
Assets - Support of mobility	0.037 (0.050)	-0.055 (0.052)	0.040 (0.052)	0.014 (0.050)	-0.004 (0.055)	0.168*** (0.065)	-0.019 (0.056)	0.131* (0.080)
Assets - Support of livelihood	0.069 (0.055)	0.049 (0.054)	0.187** (0.073)	0.237*** (0.063)	-0.016 (0.055)	0.008 (0.068)	-0.054 (0.068)	0.147* (0.079)
Household expenditure p.c.	0.109*** (0.021)	0.008 (0.022)	0.103*** (0.023)	-0.010 (0.021)	0.097*** (0.023)	-0.003 (0.028)	0.162*** (0.027)	-0.053** (0.027)
Barisal	-0.396** (0.173)	0.215 (0.293)	-0.352** (0.164)	-0.920*** (0.220)	-0.536*** (0.177)	0.155 (0.300)	-0.432*** (0.166)	0.276 (0.243)
Chittagong	-0.002 (0.168)	-0.408*** (0.124)	0.051 (0.165)	-0.551*** (0.144)	0.013 (0.146)	-0.467*** (0.172)	-0.092 (0.206)	-0.915*** (0.164)
Khulna	0.428*** (0.134)	0.341*** (0.123)	0.490*** (0.132)	0.027 (0.109)	0.514*** (0.143)	0.438*** (0.144)	0.160 (0.135)	-0.078 (0.156)
Rajshahi	-0.528*** (0.159)	-0.229 (0.223)	-0.530*** (0.165)	-0.652*** (0.204)	-0.726*** (0.161)	-0.445* (0.251)	-1.057*** (0.149)	-0.459* (0.279)
Rangpur	-0.805*** (0.120)	-0.434*** (0.122)	-0.672*** (0.136)	-0.752*** (0.117)	-0.862*** (0.128)	-0.690*** (0.147)	-1.002*** (0.135)	-1.190*** (0.138)
Sylhet	-0.002 (0.127)	-0.305* (0.163)	0.026 (0.120)	-0.404** (0.166)	-0.137 (0.131)	-0.529** (0.213)	-0.689*** (0.193)	0.092 (0.154)
F-statistic	9.12***	4.41***	6.05***	5.12***	6.53***	6.87***	10.83***	7.41***
No. of observations	2,882	2,636	2,809	3,231	2,222	1,607	1,660	1,524

Note: The table does not include the estimates of explanatory variables that are not significant in any of the regressions presented, namely, occupation of household head, nutrition, and drinking water. *** p<0.01, ** p<0.05, * p<0.1

Tables A.12.1 (sample of men) and A.12.2 (sample of women) display the estimates of Equation (2) using an ordered probit.

Table 12.1: Estimates of Equation (2) using an ordered probit– Sample of men

Variables	Domains								
	Agriculture production			Non-farming business activity			Protection from violence		
	(1)	(2)	(3)	(4)	(5)	(6)	(7)	(8)	(9)
Age	0.003 (0.002)	0.003 (0.002)	0.003 (0.002)	-0.000 (0.002)	0.001 (0.002)	0.000 (0.002)	0.000 (0.002)	0.001 (0.002)	0.000 (0.002)
Household head	0.025 (0.187)	0.012 (0.187)	0.027 (0.189)	0.231 (0.173)	0.163 (0.163)	0.238 (0.178)	0.149 (0.190)	0.078 (0.205)	0.169 (0.191)
No. of hh members	0.034** (0.017)	0.015 (0.018)	0.028 (0.017)	0.057*** (0.017)	0.043*** (0.017)	0.050*** (0.018)	0.032 (0.021)	0.028 (0.019)	0.029 (0.020)
No. of members <6	0.067* (0.036)	0.066* (0.035)	0.067* (0.036)	-0.032 (0.041)	-0.037 (0.043)	-0.025 (0.041)	0.002 (0.048)	0.005 (0.045)	0.005 (0.048)
Years of education	-0.007 (0.006)	-0.007 (0.006)	-0.011* (0.006)	-0.013* (0.007)	-0.010 (0.007)	-0.016** (0.007)	-0.001 (0.007)	-0.000 (0.007)	-0.003 (0.007)
Occupation in agriculture	0.086 (0.206)	0.128 (0.204)	0.116 (0.204)	0.251 (0.218)	0.184 (0.201)	0.299 (0.222)	-0.063 (0.271)	-0.081 (0.272)	-0.078 (0.272)
Sanitation	-0.172*** (0.062)	-0.174*** (0.062)	-0.196*** (0.062)	-0.064 (0.075)	-0.140* (0.075)	-0.090 (0.075)	-0.364*** (0.096)	-0.369*** (0.096)	-0.379*** (0.095)
Cooking fuel	-0.299** (0.141)	-0.304** (0.149)	-0.287** (0.139)	-0.373** (0.171)	-0.322* (0.173)	-0.358** (0.170)	-0.162 (0.181)	-0.177 (0.180)	-0.160 (0.188)
Assets - Access to information	0.137** (0.061)	0.137** (0.062)	0.129** (0.062)	0.089 (0.062)	0.070 (0.064)	0.079 (0.063)	-0.001 (0.065)	0.001 (0.068)	-0.001 (0.065)
Assets - Support of mobility	0.030 (0.050)	0.021 (0.050)	0.019 (0.049)	-0.006 (0.055)	-0.047 (0.053)	-0.011 (0.054)	-0.019 (0.056)	-0.051 (0.057)	-0.025 (0.056)
Assets - Support of livelihood	0.070 (0.055)	0.067 (0.052)	0.066 (0.054)	-0.015 (0.055)	-0.010 (0.053)	-0.037 (0.055)	-0.053 (0.068)	-0.077 (0.067)	-0.064 (0.068)
HH expenditure p.c.	0.110*** (0.021)	0.077*** (0.021)	0.097*** (0.021)	0.096*** (0.023)	0.068*** (0.022)	0.083*** (0.023)	0.162*** (0.027)	0.150*** (0.027)	0.155*** (0.027)
Barisal	-0.412** (0.174)	-0.493*** (0.176)	-0.430*** (0.164)	-0.542*** (0.178)	-0.647*** (0.184)	-0.573*** (0.165)	-0.428** (0.169)	-0.506*** (0.175)	-0.444*** (0.164)
Chittagong	-0.017 (0.169)	0.003 (0.161)	-0.007 (0.168)	0.007 (0.147)	0.016 (0.139)	0.006 (0.147)	-0.090 (0.207)	-0.104 (0.197)	-0.067 (0.207)
Khulna	0.426*** (0.135)	0.372*** (0.141)	0.387*** (0.134)	0.511*** (0.143)	0.426*** (0.144)	0.484*** (0.143)	0.159 (0.135)	0.188 (0.138)	0.156 (0.136)
Rajshahi	-0.507*** (0.156)	-0.275* (0.152)	-0.455*** (0.154)	-0.727*** (0.162)	-0.510*** (0.152)	-0.662*** (0.160)	-1.058*** (0.147)	-0.867*** (0.147)	-1.029*** (0.150)
Rangpur	-0.807*** (0.120)	-0.700*** (0.119)	-0.736*** (0.126)	-0.860*** (0.128)	-0.671*** (0.118)	-0.792*** (0.133)	-1.001*** (0.135)	-0.803*** (0.139)	-0.973*** (0.139)
Sylhet	-0.008 (0.127)	0.047 (0.118)	0.094 (0.124)	-0.143 (0.131)	-0.101 (0.120)	-0.018 (0.135)	-0.689*** (0.192)	-0.476** (0.187)	-0.613*** (0.196)
Feel can make decisions	0.225** (0.091)	0.150 (0.098)	0.206** (0.092)	0.092 (0.090)	0.064 (0.087)	0.079 (0.089)	-0.029 (0.081)	-0.045 (0.080)	-0.033 (0.081)
Satisfaction with decisions		0.351*** (0.040)			0.409*** (0.040)			0.310*** (0.051)	
Power to make decisions			0.081*** (0.015)			0.092*** (0.016)			0.041** (0.021)
F-statistic	9.06***	11.33***	10.00***	6.19***	12.71***	8.30***	11.03***	12.81***	10.74***
No. of observations	2,882	2,876	2,882	2,222	2,215	2,222	1,660	1,643	1,660

Note: The table does not include the estimates of explanatory variables that are not significant in any of the regressions presented, namely: occupation of household head, nutrition and drinking water. *** p<0.01, ** p<0.05, * p<0.1

Table A.12.2: Estimates of Equation (2) using an ordered probit – Sample of women

Variables	Domains								
	Agriculture production			Non-farming business activity			Protection from violence		
	(1)	(2)	(3)	(4)	(5)	(6)	(7)	(8)	(9)
Age	0.002 (0.003)	0.000 (0.003)	0.001 (0.003)	-0.001 (0.003)	-0.002 (0.003)	-0.001 (0.003)	0.004 (0.004)	0.002 (0.004)	0.003 (0.004)
Household head	-0.022 (0.089)	-0.053 (0.093)	-0.032 (0.091)	0.114 (0.129)	0.089 (0.136)	0.106 (0.133)	0.258*** (0.081)	0.246*** (0.089)	0.251*** (0.083)
No. of household members	0.007 (0.018)	0.007 (0.017)	0.007 (0.018)	0.014 (0.025)	0.008 (0.023)	0.012 (0.025)	-0.005 (0.023)	-0.019 (0.022)	-0.006 (0.024)
No. of members <6	0.073* (0.041)	0.072* (0.041)	0.054 (0.040)	-0.129*** (0.041)	-0.120*** (0.042)	-0.137*** (0.042)	0.087 (0.055)	0.076 (0.058)	0.079 (0.053)
Years of education	0.008 (0.008)	0.004 (0.009)	0.005 (0.008)	0.004 (0.010)	-0.005 (0.011)	0.003 (0.010)	0.026** (0.011)	0.023** (0.012)	0.024** (0.011)
Occupation in agriculture	-0.233*** (0.062)	-0.262*** (0.063)	-0.211*** (0.062)	-0.106 (0.070)	-0.121* (0.069)	-0.099 (0.069)	-0.197** (0.080)	-0.185** (0.081)	-0.199** (0.081)
Sanitation	0.119* (0.061)	0.077 (0.062)	0.105* (0.063)	0.110 (0.079)	0.099 (0.081)	0.101 (0.079)	0.175** (0.088)	0.141 (0.093)	0.171* (0.087)
Cooking fuel	-0.217 (0.135)	-0.157 (0.125)	-0.223 (0.137)	-0.071 (0.193)	0.047 (0.180)	-0.081 (0.191)	-0.305 (0.191)	-0.209 (0.181)	-0.305 (0.193)
Assets - Access to information	0.074 (0.067)	0.028 (0.070)	0.066 (0.066)	0.150* (0.078)	0.147* (0.079)	0.153** (0.077)	0.058 (0.084)	0.028 (0.087)	0.054 (0.085)
Assets - Support of mobility	-0.051 (0.052)	-0.086* (0.051)	-0.041 (0.051)	0.170*** (0.065)	0.102 (0.065)	0.165*** (0.064)	0.132* (0.080)	0.121 (0.079)	0.142* (0.079)
Assets - Support of livelihood	0.048 (0.054)	0.017 (0.054)	0.044 (0.053)	0.003 (0.067)	0.002 (0.069)	-0.012 (0.067)	0.148* (0.079)	0.153* (0.084)	0.139* (0.078)
Household expenditure p.c.	0.006 (0.022)	-0.001 (0.022)	-0.015 (0.023)	-0.005 (0.028)	-0.019 (0.028)	-0.021 (0.029)	-0.053* (0.027)	-0.050* (0.028)	-0.062** (0.028)
Barisal	0.223 (0.293)	0.203 (0.283)	0.260 (0.293)	0.139 (0.301)	0.131 (0.276)	0.182 (0.299)	0.272 (0.243)	-0.003 (0.240)	0.267 (0.240)
Chittagong	-0.389*** (0.126)	-0.474*** (0.134)	-0.376*** (0.126)	-0.451*** (0.174)	-0.515*** (0.186)	-0.435** (0.174)	-0.912*** (0.164)	-1.062*** (0.165)	-0.883*** (0.163)
Khulna	0.348*** (0.123)	0.270** (0.121)	0.349*** (0.118)	0.428*** (0.143)	0.344** (0.143)	0.433*** (0.144)	-0.084 (0.156)	-0.289** (0.131)	-0.094 (0.163)
Rajshahi	-0.229 (0.222)	-0.215 (0.206)	-0.240 (0.210)	-0.446* (0.249)	-0.411* (0.228)	-0.437* (0.245)	-0.461* (0.279)	-0.579** (0.231)	-0.476* (0.270)
Rangpur	-0.420*** (0.123)	-0.405*** (0.127)	-0.430*** (0.123)	-0.675*** (0.149)	-0.612*** (0.146)	-0.670*** (0.149)	-1.189*** (0.139)	-1.095*** (0.157)	-1.204*** (0.142)
Sylhet	-0.281* (0.166)	-0.262* (0.154)	-0.233 (0.162)	-0.529** (0.216)	-0.517** (0.203)	-0.478** (0.216)	0.088 (0.154)	-0.041 (0.145)	0.101 (0.158)
Feel can make decisions	0.105* (0.054)	0.046 (0.053)	0.057 (0.053)	0.111* (0.062)	0.040 (0.065)	0.090 (0.062)	0.023 (0.070)	-0.053 (0.075)	0.012 (0.071)
Satisfaction with decisions		0.372*** (0.038)			0.367*** (0.048)			0.501*** (0.052)	
Power to make decisions			0.079*** (0.015)			0.050*** (0.017)			0.043* (0.022)
F-statistic	4.521***	10.456***	6.647***	7.053***	11.410***	7.095***	7.060***	11.494***	6.522***
No. of observations	2,636	2,562	2,636	1,607	1,509	1,607	1,523	1,417	1,523

Note: The table does not include the estimates of explanatory variables that are not significant in any of the regressions presented, namely, occupation of household head, nutrition, and drinking water. *** p<0.01, ** p<0.05, * p<0.1

Additional References

- Abdi, H. and Valentin, D. (2007). 'Multiple correspondence analysis', In: Salkind N. J. (Ed.), *Encyclopedia of Measurement and Statistics*. Thousand Oaks, CA: Sage Publications; pp. 651–657.
- Mokken, R. J. (1971). *A Theory and Procedure of Scale Analysis*. Berlin: De Gruyter.
- Sijtsma, K., Meijer, R. R., and Van der Ark, L. A. (2011). 'Mokken scale analysis as time goes by: An update for scaling practitioners', *Personality and Individual Differences*, 50, pp. 31–37.